

# Engineering Data

## Hydronic-H Super



# CONTENTS

<b>Part 1 General Information</b>	<b>3</b>
<b>Part 2 Engineering Data</b>	<b>13</b>
<b>Part 3 Installation and Field Settings</b>	<b>32</b>



# Part 1

# General Information

<b>1 System introduction</b>	<b>4</b>
<b>2 Product lineup</b>	<b>10</b>
<b>3 System Design and Unit Selection</b>	<b>11</b>

## 1 System introduction

### 1.1 System Schematic

Hydronic-H Super is an integrated air-to-water space heating and space cooling heat pump system. The outdoor heat pump system extracts heat from the outdoor air and transfers this heat through refrigerant piping to the plate heat exchanger in the hydronic system. The heated water in the hydronic system circulates to low temperature heat emitters (floor heating loops or low temperature radiators) to provide space heating. The 4-way valve in the outdoor unit can reverse the refrigerant cycle so that the hydronic system can provide chilled water for cooling using fan coil units.

The heating capacity of heat pumps decreases with the decrease of ambient temperature. Hydronic-H Super is reserved an auxiliary electric heater control port to provide additional heating capacity for use during extremely cold weather when the heat pump capacity is insufficient. The auxiliary electric heater also serves as a backup in case of heat pump malfunction and for anti-freeze protection of the outside water piping in winter.

### 1.2 Typical Applications

#### 1.2.1 Air Conditioning mode

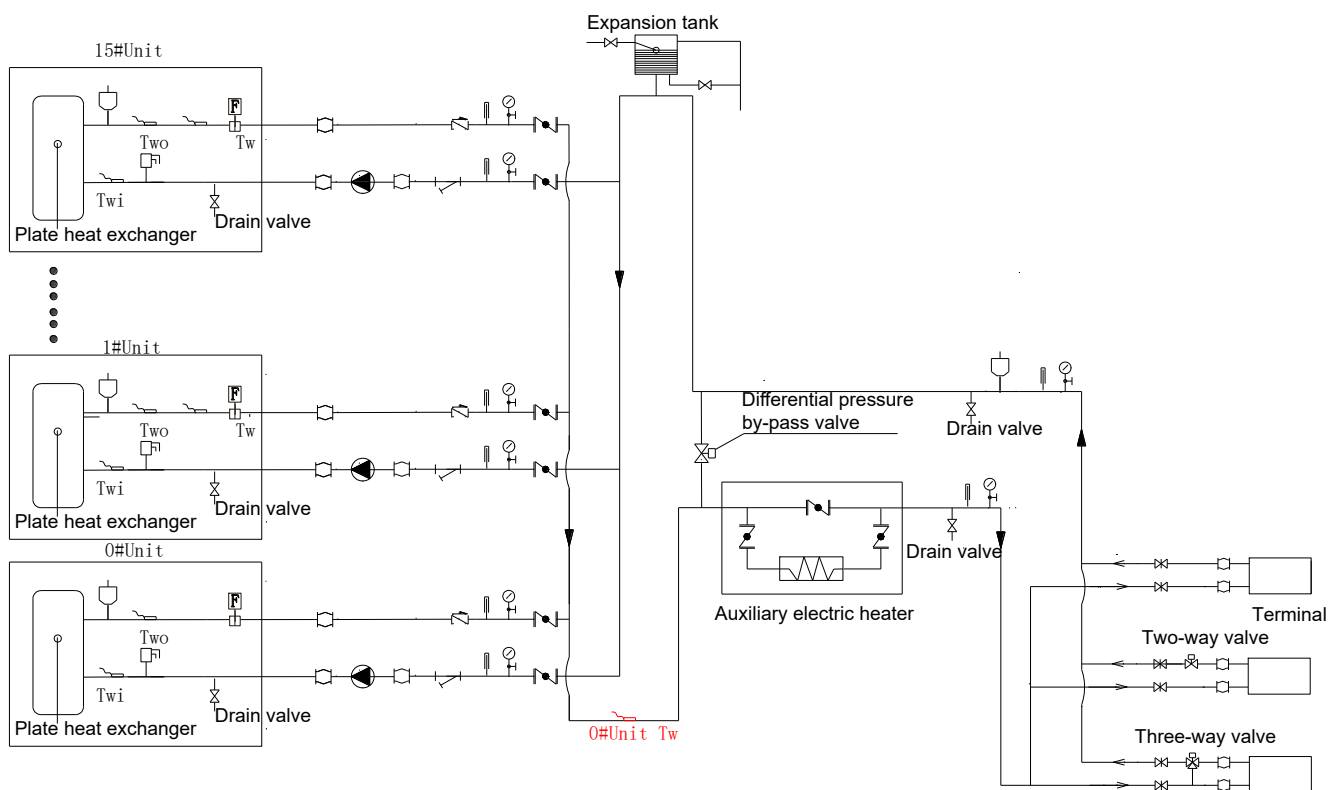

Symbol explanation				
Drain valve	Water pressure instrument	Water flow switch	Gate valve	Differential pressure by-pass valve
Y-filter	Thermometer	Pump	Check valve	Atmospheric exhaust valve
Expansion tank	Safety valve	Soft joint	Solenoid three-way valve	

- Note:
1. The ratio of the two - way valves on the terminal shall not exceed 50 percent.
  2. The main outlet water temperature sensing (Tw) head of the unit at address 0 needs to be placed on the main outlet pipe.
  3. The hot water tank and the hot water exchange pump of the unit use the CN125(220V)port control switch on the slave board of the 0 # unit, pump output is controlled through CN108 (0-10V). (CN125 is a three-way valve control port for switching between hot water mode and air conditioning mode)

## 1.2.2 Air Conditioning mode (unit with variable frequency pump)

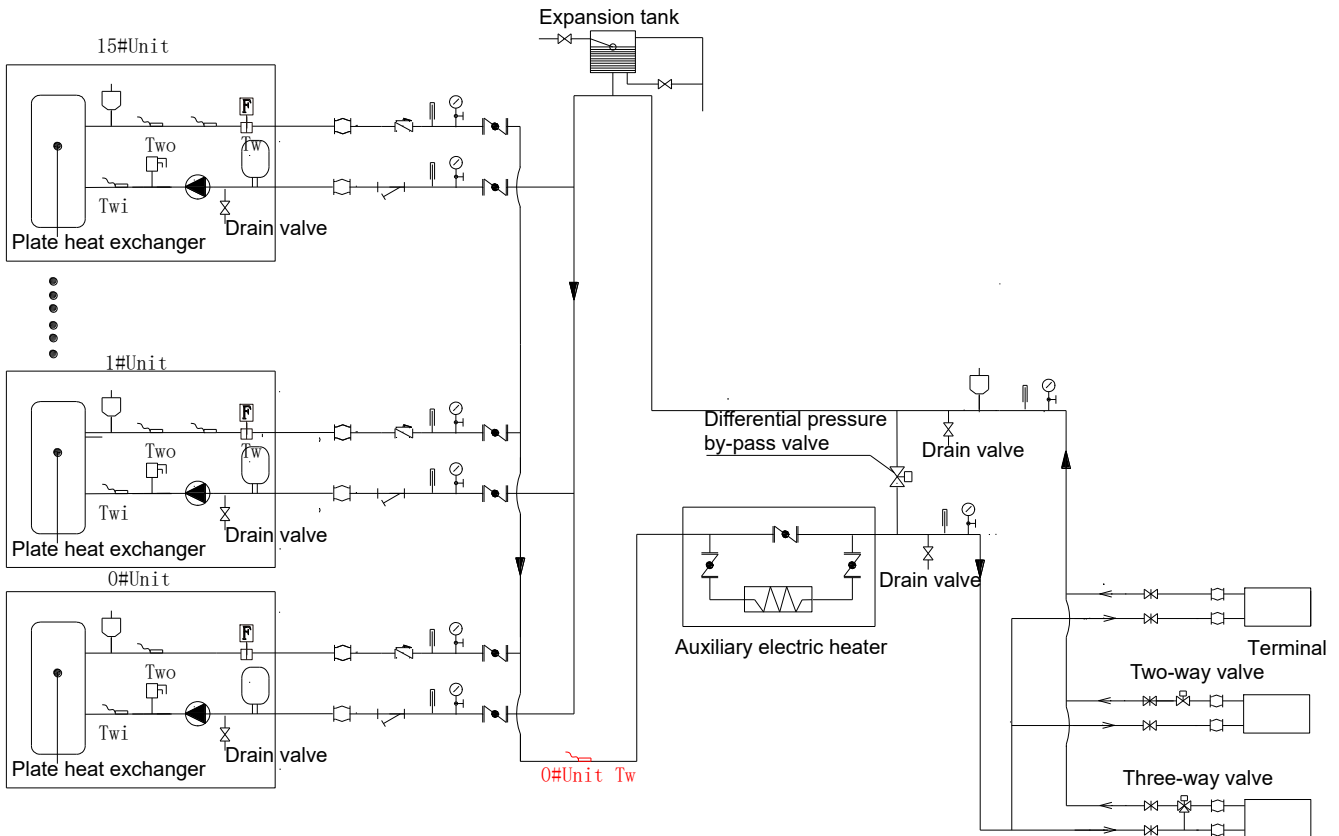

Symbol explanation				
Drain valve	Water pressure instrument	Water flow switch	Gate valve	Differential pressure by-pass valve
Y-filter	Thermometer	Pump	Check valve	Atmospheric exhaust valve
Expansion tank	Safety valve	Soft joint	Solenoid three-way valve	

- Note:
1. The ratio of the two - way valves on the terminal shall not exceed 50 percent.
  2. The main outlet water temperature sensing (Tw) head of the unit at address 0 needs to be placed on the main outlet pipe.
  3. The hot water tank and the hot water exchange pump of the unit use the CN125 ( 220V ) port control switch on the slave board of the 0 # unit, pump output is controlled through CN108 ( 0-10V ). (CN125 is a three-way valve control port for switching between hot water mode and air conditioning mode)

## 1.2.3 Air conditioning and hot water mode

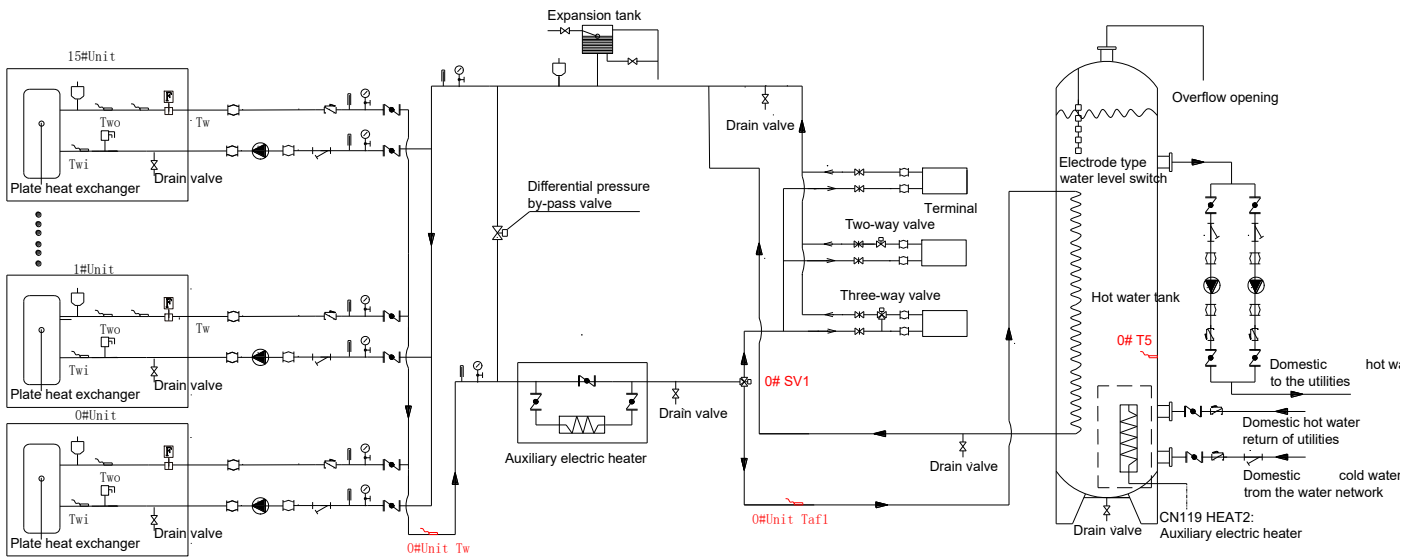
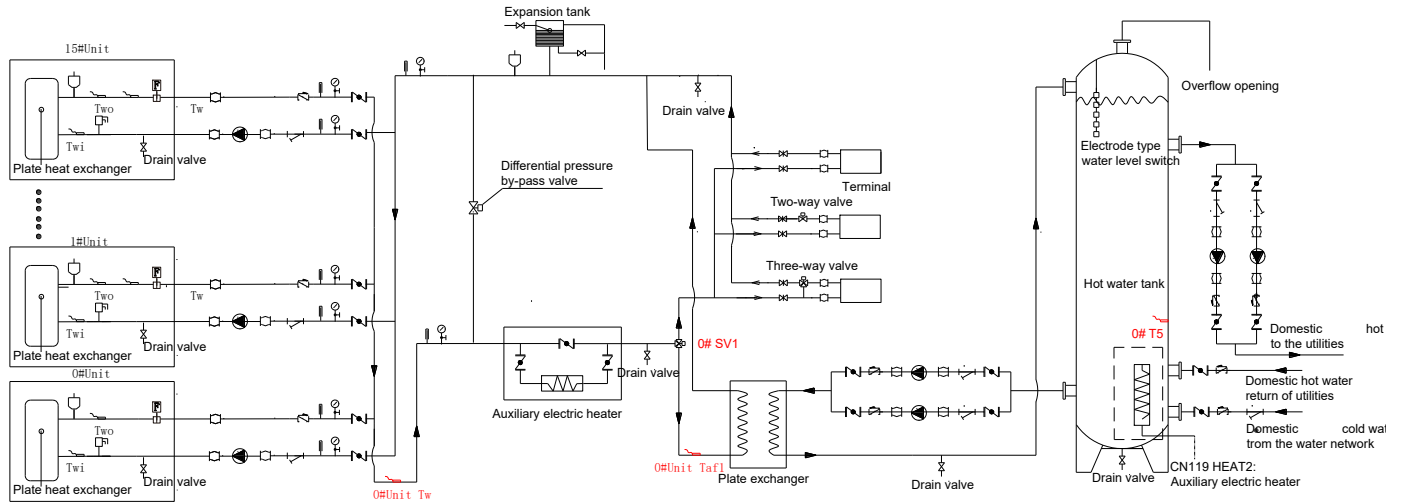

Symbol explanation				
Drain valve	Water pressure instrument	Water flow switch	Gate valve	Differential pressure by-pass valve
Y-filter	Thermometer	Pump	Check valve	Atmospheric exhaust valve
Expansion tank	Safety valve	Soft joint	Solenoid three-way valve	

- Note:
1. The ratio of the two - way valves on the terminal shall not exceed 50 percent.
  2. The main outlet water temperature sensing (Tw) head of the unit at address 0 needs to be placed on the main outlet pipe.
  3. The hot water tank and the hot water exchange pump of the unit use the CN125 ( 220V ) port control switch on the slave board of the 0 # unit, pump output is controlled through CN108 ( 0-10V ). (CN125 is a three-way valve control port for switching between hot water mode and air conditioning mode)

## 1.2.4 Air conditioning and hot water mode (unit with variable frequency pump)

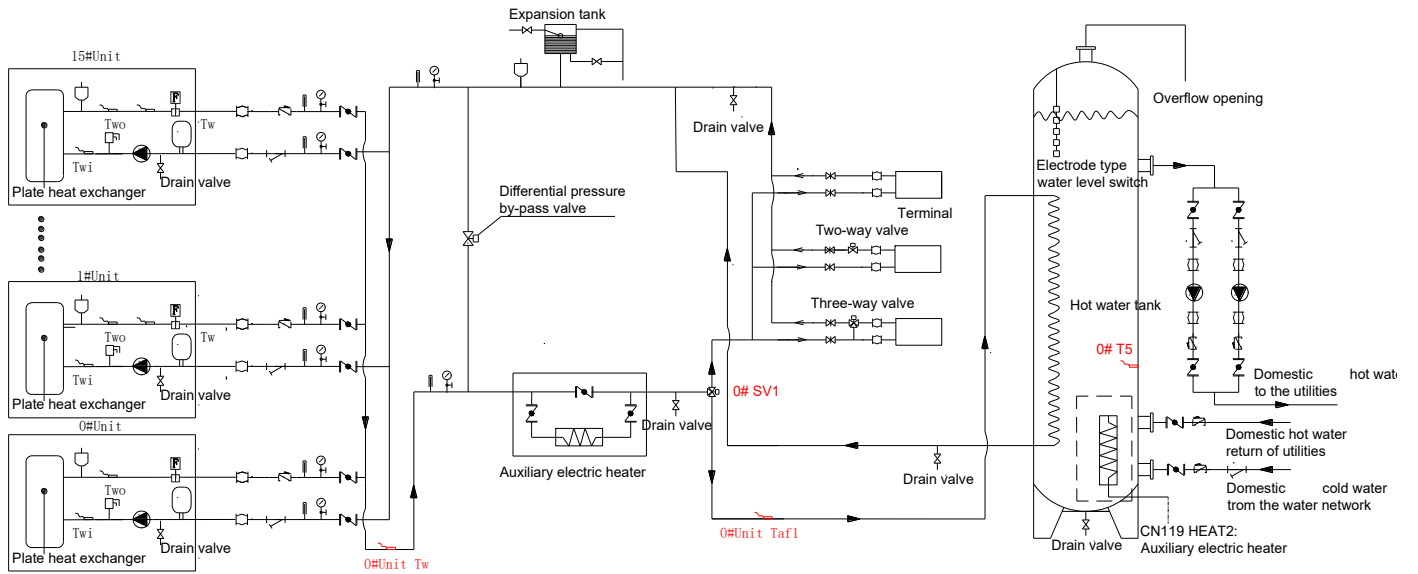
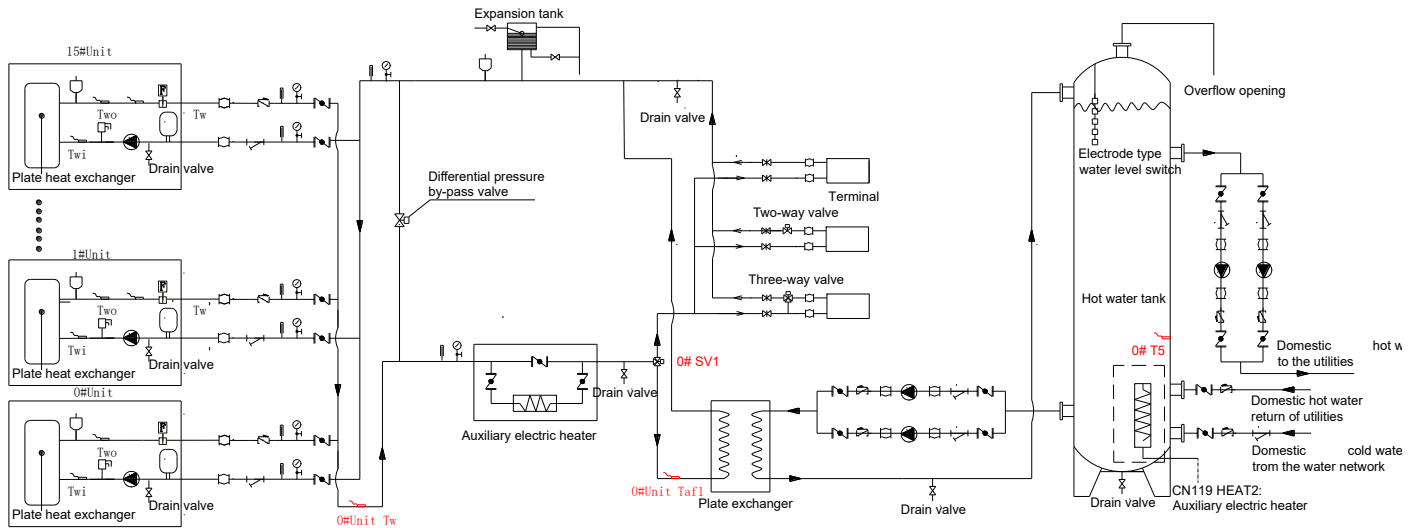

Part 1 - General Information

Symbol explanation				
Drain valve	Water pressure instrument	Water flow switch	Gate valve	Differential pressure by-pass valve
Y-filter	Thermometer	Pump	Check valve	Atmospheric exhaust valve
Expansion tank	Safety valve	Soft joint	Solenoid three-way valve	

- Note:
1. The ratio of the two - way valves on the terminal shall not exceed 50 percent.
  2. The main outlet water temperature sensing (Tw) head of the unit at address 0 needs to be placed on the main outlet pipe.
  3. The hot water tank and the hot water exchange pump of the unit use the CN125 (220V) port control switch on the slave board of the 0 # unit, pump output is controlled through CN108 (0-10V). (CN125 is a three-way valve control port for switching between hot water mode and air conditioning mode)

## 1.2.5 Cooling and hot water mode are operated simultaneously

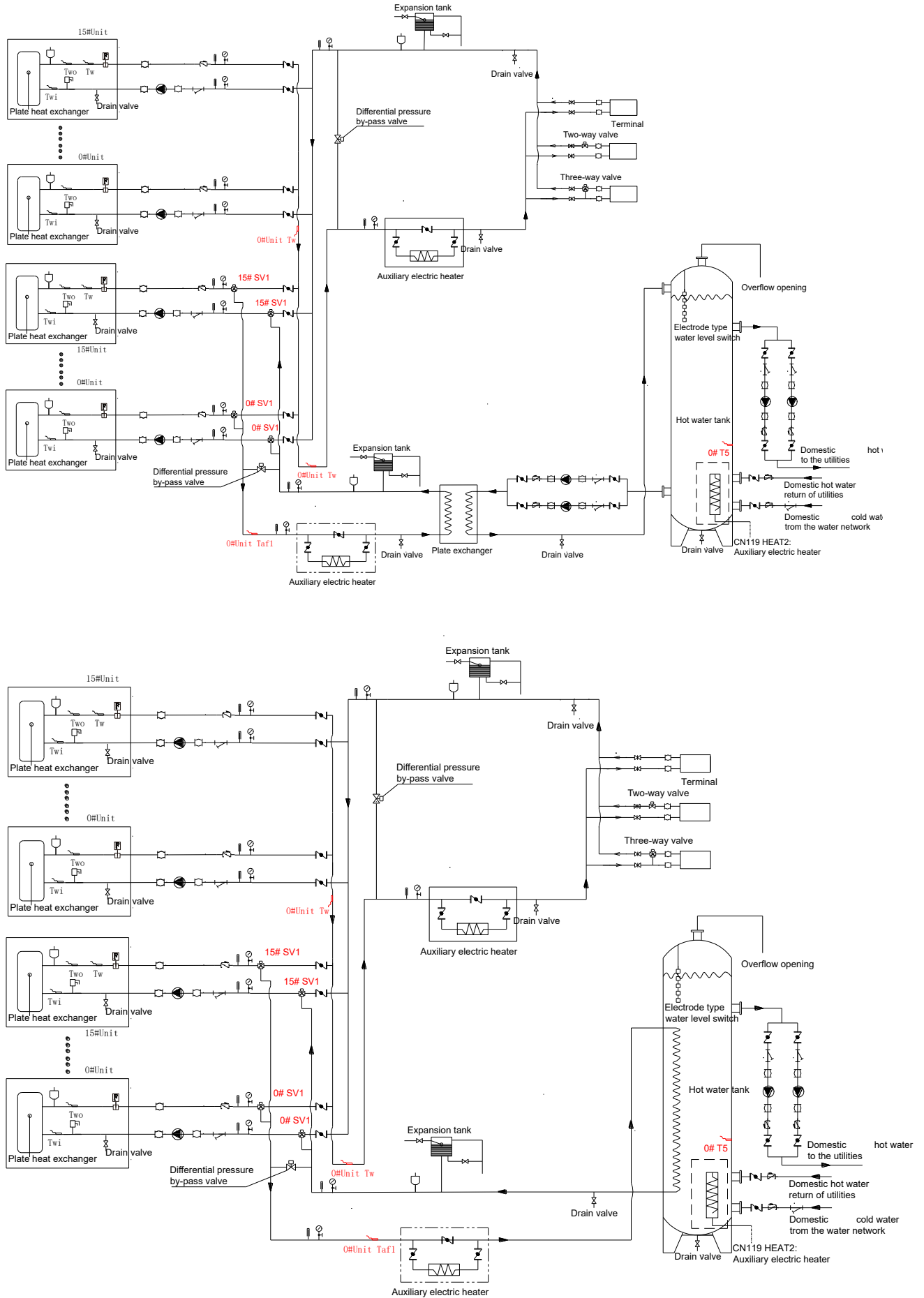

## 1.2.6 Cooling and hot water mode are operated simultaneously (unit with variable frequency pump)

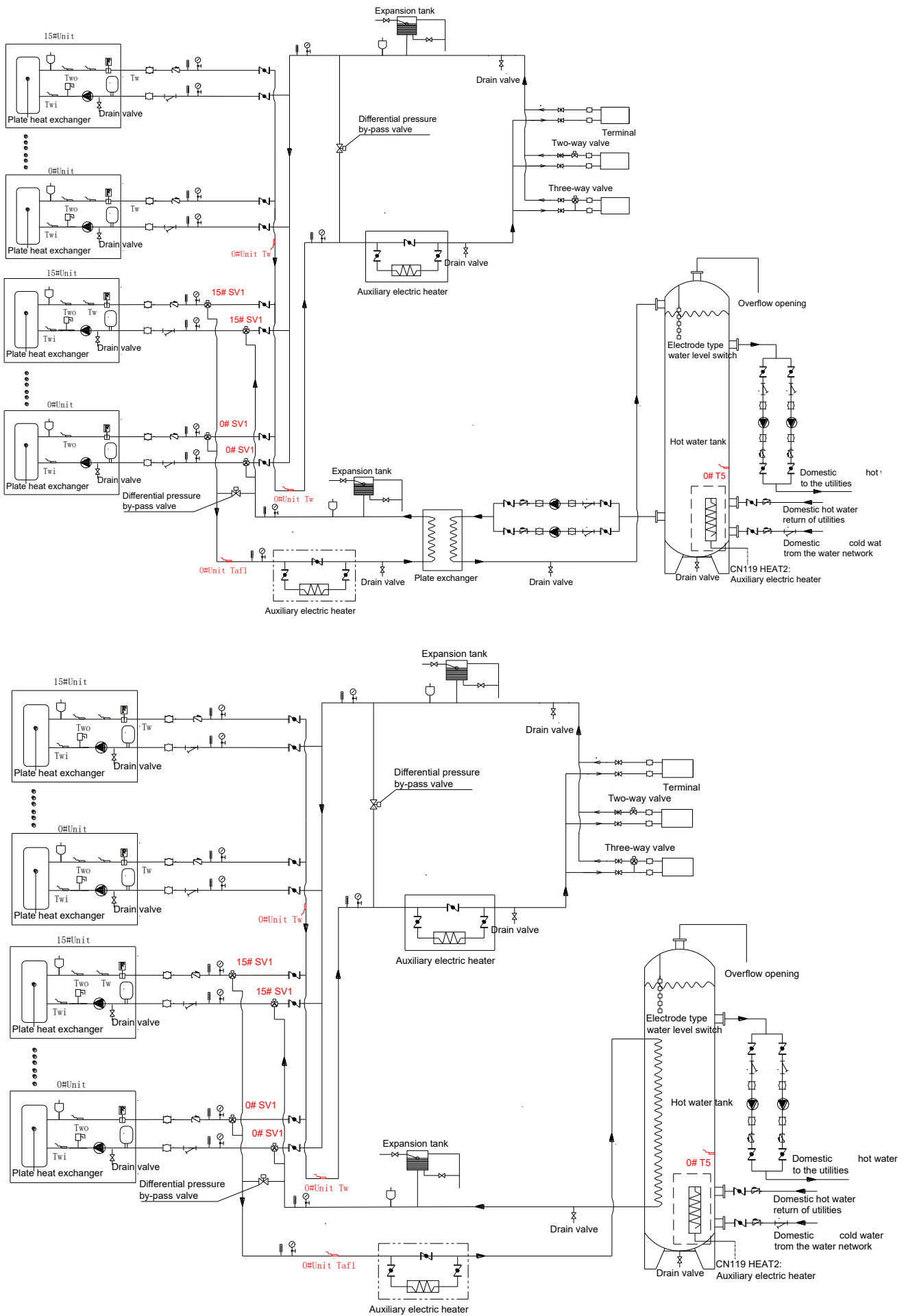

**2 Product lineup**

Model	HMDC-M65T3 HMDC-M75T3	HMDC-M110T3 HMDC-M140T3
Power supply	380-415V/3Ph/50Hz	380-415V/3Ph/50Hz
Appearance		

### 3 System Design and Unit Selection

#### 3.1 Selection Procedure

**Step 1: Total heat load calculation**

Calculate conditioned surface area  
 Select the heat emitters (type, quantity, water temperature and heat load)

**Step 2: System configuration**

Decide whether to enable or disable auxiliary electric heater

**Step 3: Selection of outdoor units**

Determine required total heat load on outdoor units  
 Set capacity safety factor  
 Select power supply

Provisionally select Hydronic-H Super Series unit capacity<sup>1</sup> based on nominal capacity

Correct capacity of the outdoor units for the following items:  
 Outdoor air temperature / Outdoor humidity / Water outlet temperature<sup>2</sup> /  
 Altitude / Anti-freeze type

Is corrected Hydronic-H Super capacity  $\geq$  Required total heat load on outdoor units<sup>3</sup>

Yes  
 Hydronic-H Super system selection is complete

No  
 Select a larger model or enable auxiliary electric heater operation

Part 1 - General Information

**Notes:**

1. Up to 16 units can be connected together, giving a system cooling/heating capacity range from 65kW to 2240kW.
2. If the required water temperatures of the heat emitters are not all the same, the Hydronic-H Super's outlet water temperature setting should be set at the highest of the heat emitter required water temperatures. If the water outlet design temperature falls between two temperatures listed in the outdoor unit's capacity table, calculate the corrected capacity by interpolation.
3. Select Hydronic-H Super which satisfies both total heating and cooling load requirements.

#### 3.2 Modular Chiller Leaving Water Temperature (LWT) Selection

The recommended design LWT ranges for different types of heat emitter are:

- For floor heating: 35 to 45°C
- For fan coil units: 40 to 45°C
- For low temperature radiators: 40 to 50°C

### 3.3 Optimizing System Design

To get the most comfort with the lowest energy consumption with Hydronic-H Super, it is important to take account of the following considerations:

- Choose heat emitters that allow the heat pump system to operate at as low a hot water temperature as possible whilst still providing sufficient heating.

### 3.4 Design of the buffer tank in the system

To prevent excessive temperature changes in the water system during the defrosting process of the unit, or frequent startup and shutdown during use, a buffer tank should be installed in the water system. The recommended calculation method for the volume of the buffer tank is as follows:

$$M = \frac{k \times Q \times T}{C \times \Delta t \times \rho} - M1$$

- n: the equation,
- M: The volume of the buffer water tank, unit: L,
- k: Defrosting capacity coefficient, taken as 0.4 based on the test result,
- Q: Unit heating capacity, unit: kW,
- T: The maximum defrosting time, unit: S, taken as 240 based on the test result,
- C: Specific heat capacity of heat exchange liquid, unit: kJ/kg °C,
- Δt: Allowable water temperature drop during defrosting process, unit: °C, usually taken as 3,
- ρ : The density of the heat exchange liquid, in kg/L,
- M1: Pipeline volume, unit: L; need to consider the minimum amount of circulating water that can occur in the system.

The selection of k and T parameters is based on the test results of the unit. The refrigeration capacity of the unit during defrosting is 0.4. The time T is around 200S. To have margin, it is recommended to choose 240S. The Δt is recommended to choose 3°C according to our company's standard.

For a single unit water system, it is recommended to add a buffer water tank in the waterway and select the type according to the above formula. For a water system with multiple units in parallel, the capacity selection of the buffer water tank can be based on a single unit.

# Part 2

# Engineering Data

<b>1 Specifications</b>	<b>14</b>
<b>2 Electrical Characteristics</b>	<b>16</b>
<b>3 Dimensions and Center of Gravity</b>	<b>17</b>
<b>4 Capacity Tables</b>	<b>19</b>
<b>5 Performance Adjustment Factors</b>	<b>27</b>
<b>6 Hydronic Performance</b>	<b>29</b>
<b>7 Octave Band Levels</b>	<b>30</b>

## 1 Specifications

Model		HMDC-M65T3	HMDC-M75T3	HMDC-M110T3	HMDC-M140T3
Power supply		V/Ph/Hz	380~415/3/50	380~415/3/50	380~415/3/50
Cooling(A35W7)	Capacity	kW	57	70	100
	Input	kW	19.00	26.80	32.78
	EER		3.00	2.61	3.05
Cooling(A35W18)	Capacity	kW	76	86	128
	Input	kW	20.27	23.12	33.70
	EER		3.75	3.72	3.80
SEER			5.00	5.00	4.80
Heating(A7W65)	Capacity	kW	60	61	100
	Input	kW	26.10	26.75	42.90
	COP		2.30	2.28	2.33
Heating(A7W55)	Capacity	kW	64	66	106
	Input	kW	21.33	22.15	35.30
	COP		3.00	2.98	3.00
Heating(A7W45)	Capacity	kW	65	75	110
	Input	kW	18.30	22.06	29.90
	COP		3.55	3.40	3.68
Heating(A7W35)	Capacity	kW	64	77	112
	Input	kW	15.24	19.74	27.00
	COP		4.20	3.90	4.15
SCOP(55)average			3.40	3.40	3.25
SCOP(35)average			4.50	4.50	4.25
Fan	Type		DC motor	DC motor	DC motor
	Quantity		2	2	2
	Air flow rate	m <sup>3</sup> /h	22000	28500	32500
Air side heat exchanger	Type		Fin coil mode	Fin coil mode	Fin coil mode
	Row		2	2	2
	thickness	mm	0.095	0.095	0.095
	pipe diameter	mm	7	7	7
Water side heat exchanger	Type		Plate heat exchanger	Plate heat exchanger	Plate heat exchanger
	Water pressure drop	kPa	44	65	39
	Volume	L	5.17	5.17	11.1
	Rated water flow(cooling)	m <sup>3</sup> /h	9.8	12.04	17.2
	Rated water flow(heating)	m <sup>3</sup> /h	11.2	12.9	18.9
	Water flow range	m <sup>3</sup> /h	3~14	3~14	5~26
Refrigerant system	Type		R32	R32	R32
	Charge	kg	9	9	15.5

Throttle type		EXV	EXV	EXV	EXV
Sound power level (A7W45)	dB(A)	80	86	80	92
Sound pressure level(1m) <sup>1</sup> (A7W45)	dB(A)	64	69	64	73
Silent mode sound power level(A7W45)	dB(A)	77	82	75	88
Super Silent mode sound power level(A7W45)	dB(A)	74	78	72	85
Net dimensions(W×H×D)	mm	2000X1770X960	2000X1770X960	2220×2300×1135	2220×2300×1135
Packed dimensions (W×H×D)	mm	2085X1890X1030	2085X1890X1030	2250×2445×1180	2250×2445×1180
Net / Gross weight	kg	440 / 455	440 / 455	670 / 690	670 / 690
Water pipe connection	mm	DN50	DN50	DN65	DN65
Ambient temperature range	Cooling	°C	-15 to 48	-15 to 48	-15 to 48
	Heating	°C	-25 to 43	-25 to 43	-25 to 43
	DHW	°C	-20 to 43	-20 to 43	-20 to 43
Water outlet temperature range	Cooling <sup>2</sup>	°C	0 to 20	0 to 20	0 to 20
	Heating	°C	25 to 65	25 to 65	25 to 65
	DHW(Heat pump)	°C	30 to 62	30 to 62	30 to 62
	DHW <sup>3</sup>	°C	30 to 70	30 to 70	30 to 70

**Notes:**

1. Sound pressure level is the test average measured in a semi-anechoic chamber. The test position is 1m right in front of the unit for four sides and  $(1+H)/2$ m (where H is the height of the unit) above the floor. During in-situ operation, sound pressure levels may be higher as a result of ambient noise.

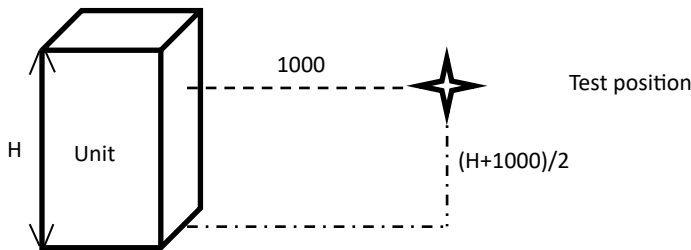

2. Antifreeze fluid is need when water temperature is less than 5°C.
3. Heat pump + Electric heater, Electric heater installed in the tank is field supplied.

## 2 Electrical Characteristics

System	Outdoor unit				Power current		Compressor		Fan	
	Voltage	Hz	Min.	Max.	MCA	MOP	MSC	RLA	kW	FLA
	(V)		(V)	(V)	(A)	(A)	(A)	(A)		(A)
HMDC-M65T3	380-415	50	342	456	46	54	-	34.09	0.39	1.4
HMDC-M75T3	380-415	50	342	456	46	54	-	34.09	0.72	2.5
HMDC-M110T3	380-415	50	342	456	90	106	-	34.09	0.68	1.7
HMDC-M140T3	380-415	50	342	456	90	106	-	34.09	1.60	4.0

Note:

MCA: Min. Circuit Amps. (For wire diameter selection)

MOP: Maximum overcurrent protector

MSC : Max. Starting Amps.

FLA: Full Load Amps.

KW: Rated Motor Output

RLA: In nominal cooling or heating test condition, the input Amps of compressor where MAX. Hz can operate Rated Load Amps.

## 3 Dimensions and Center of Gravity

HMDC-M65T3 / HMDC-M75T3

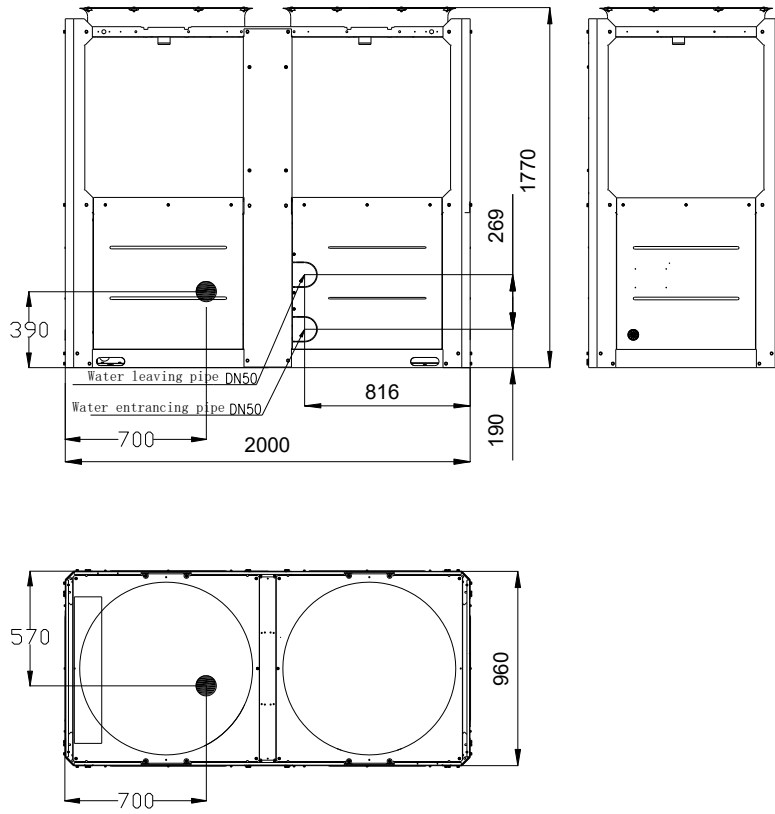

HMDC-M110T3 / HMDC-M140T3

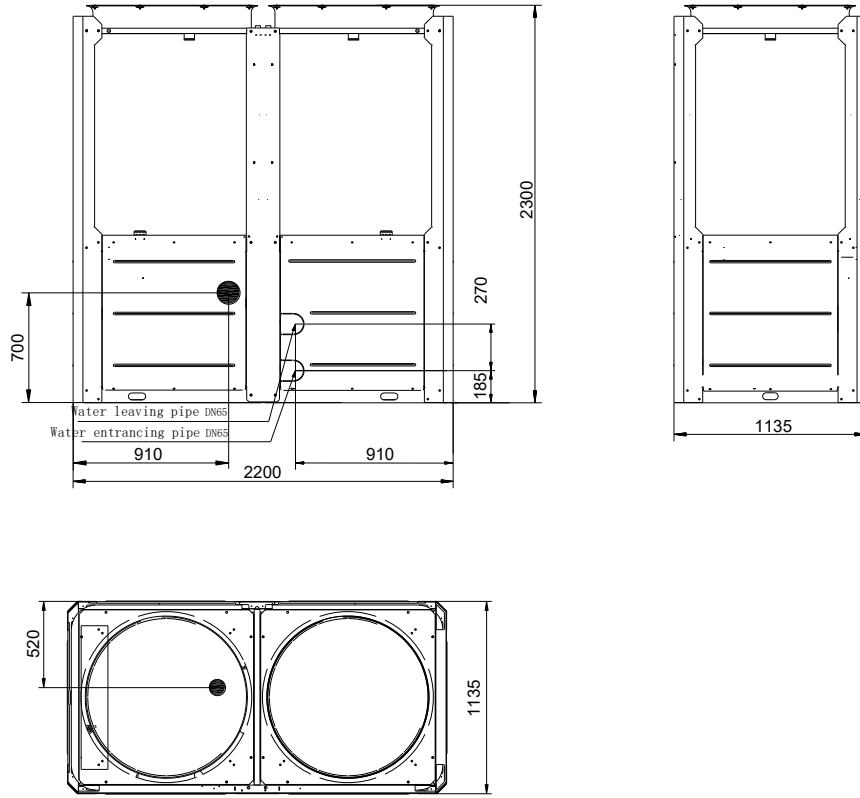

## 4 Capacity Tables

### 4.1 Heating Capacity Tables

#### HMDC-M65T3

LWT	DB																	
	-25			-20			-18			-15			-10			-5		
	HC	PI	EER	HC	PI	EER	HC	PI	EER	HC	PI	EER	HC	PI	EER	HC	PI	EER
25	34.40	16.05	2.14	40.00	15.68	2.55	43.38	15.02	2.89	46.15	14.89	3.10	49.10	15.72	3.12	55.17	16.98	3.25
30	32.03	17.02	1.88	37.25	16.62	2.24	42.08	15.36	2.74	44.77	15.10	2.97	47.62	15.82	3.01	53.19	17.07	3.12
35	32.47	18.98	1.71	37.76	18.53	2.04	40.15	16.59	2.42	42.71	16.36	2.61	45.44	17.19	2.64	50.78	18.46	2.75
40	30.11	19.55	1.54	35.01	19.10	1.83	40.21	20.40	1.97	42.78	19.93	2.15	45.51	20.75	2.19	51.44	21.35	2.41
45	\	\	\	35.10	22.68	1.55	39.34	22.70	1.73	41.85	21.94	1.91	44.53	22.64	1.97	51.15	24.05	2.13
48	\	\	\	33.71	27.27	1.24	38.49	27.80	1.38	40.95	25.10	1.63	43.56	24.40	1.79	50.52	25.47	1.98
50	\	\	\	\	\	\	36.20	26.35	1.37	38.51	23.79	1.62	40.97	24.00	1.71	48.47	26.05	1.86
55	\	\	\	\	\	\	\	\	\	37.36	24.14	1.55	39.74	24.17	1.64	47.64	26.58	1.79
60	\	\	\	\	\	\	\	\	\	\	\	\	38.47	25.86	1.49	45.67	28.15	1.62
65	\	\	\	\	\	\	\	\	\	\	\	\	36.30	27.44	1.32	43.78	30.36	1.44
LWT	DB																	
	0			5			7			10			15			20		
	HC	PI	EER	HC	PI	EER	HC	PI	EER	HC	PI	EER	HC	PI	EER	HC	PI	EER
25	61.23	17.56	3.49	64.88	17.59	3.69	68.96	16.00	4.31	72.27	15.92	4.54	84.00	17.32	4.85	86.77	17.44	4.98
30	58.76	17.99	3.27	62.23	17.67	3.52	66.51	15.65	4.25	71.02	16.42	4.33	79.24	16.82	4.71	83.50	17.30	4.83
35	56.13	18.31	3.06	59.56	17.69	3.37	64.00	15.24	4.20	66.41	15.52	4.28	76.43	16.75	4.56	80.79	17.24	4.69
40	57.37	20.57	2.79	61.17	19.27	3.18	64.83	18.03	3.60	67.21	17.53	3.83	74.30	17.55	4.23	75.58	16.80	4.50
45	57.77	22.75	2.54	61.75	20.56	3.00	65.00	18.31	3.55	65.85	17.93	3.67	68.53	17.26	3.97	73.73	17.64	4.18
48	57.47	24.40	2.36	61.63	20.96	2.94	64.83	20.10	3.23	65.82	18.38	3.58	68.49	17.69	3.87	73.69	18.08	4.08
50	55.98	25.62	2.18	61.19	21.32	2.87	64.51	20.50	3.15	65.30	18.63	3.51	67.96	17.93	3.79	73.12	18.32	3.99
55	55.53	26.39	2.10	60.70	21.96	2.76	64.00	21.30	3.00	63.95	20.79	3.08	66.55	20.01	3.33	71.60	20.45	3.50
60	52.87	27.76	1.90	58.67	23.45	2.50	61.95	22.82	2.72	59.45	21.61	2.75	61.86	21.19	2.92	59.82	19.65	3.04
65	51.26	30.28	1.69	56.82	25.55	2.22	60.00	25.00	2.40	54.95	22.71	2.42	57.18	22.75	2.51	43.47	16.79	2.59
LWT	DB																	
	25			30			35			40			43					
	HC	PI	EER	HC	PI	EER	HC	PI	EER	HC	PI	EER	HC	PI	EER			
25	91.83	17.48	5.25	97.83	16.73	5.85	98.70	14.96	6.60	99.77	14.44	6.91	98.63	13.48	7.32			
30	90.57	17.67	5.13	99.39	17.75	5.60	102.3	16.01	6.39	106.1	16.33	6.50	101.1	14.99	6.74			
35	88.67	17.47	5.07	98.30	18.32	5.37	104.6	17.66	5.94	108.7	18.05	6.02	102.4	16.05	6.38			
40	83.15	17.17	4.84	90.99	18.46	4.93	97.13	17.30	5.61	101.6	17.84	5.69	95.17	15.85	6.00			
45	80.83	18.02	4.49	82.17	17.46	4.71	88.73	16.66	5.33	90.75	16.84	5.39	85.65	15.16	5.65			
48	80.78	18.48	4.37	82.12	17.90	4.59	88.69	17.08	5.19	90.70	17.27	5.25	85.61	15.54	5.51			
50	80.15	18.72	4.28	81.48	18.14	4.49	87.99	17.31	5.08	89.99	17.50	5.14	84.94	15.75	5.39			
55	78.49	20.90	3.76	79.79	20.25	3.94	86.17	19.32	4.46	88.13	19.53	4.51	83.18	17.58	4.73			
60	65.27	20.42	3.20	62.50	19.26	3.25	67.49	18.17	3.72	69.03	18.37	3.76	65.15	16.53	3.94			
65	47.65	17.16	2.78	48.44	16.63	2.91	52.31	15.51	3.37	35.89	10.05	3.57	\	\	\			

Abbreviations:

HC: Total heating capacity (kW)

PI: Power input (kW)

LWT: Leaving water temperature (°C)

DB: Dry-bulb temperature for outdoor air temperature (°C)

Performance specifications measured with water pump operating at rated water flow rate.

LWT	DB																	
	-25			-20			-18			-15			-10			-5		
	HC	PI	EER	HC	PI	EER	HC	PI	EER	HC	PI	EER	HC	PI	EER	HC	PI	EER
25	39.56	20.16	1.96	46.22	19.75	2.34	50.13	18.58	2.70	53.33	19.44	2.74	56.74	20.35	2.79	63.75	21.68	2.94
30	37.52	21.77	1.72	43.84	21.33	2.06	49.53	19.34	2.56	52.69	20.08	2.62	56.06	20.86	2.69	62.61	22.20	2.82
35	36.57	23.34	1.57	42.73	22.86	1.87	45.43	20.09	2.26	48.33	20.92	2.31	51.42	21.79	2.36	57.46	23.08	2.49
40	33.74	23.87	1.41	39.21	23.32	1.68	45.04	24.45	1.84	47.92	25.22	1.90	50.98	26.04	1.96	57.62	26.43	2.18
45	\	\	\	38.73	27.27	1.42	42.27	26.09	1.62	46.84	27.75	1.69	49.83	28.38	1.76	57.25	29.74	1.93
48	\	\	\	36.28	29.98	1.21	39.60	29.33	1.35	43.88	28.32	1.55	46.68	28.96	1.61	53.63	30.35	1.77
50	\	\	\	\	\	\	38.66	29.29	1.32	42.85	28.19	1.52	45.58	28.83	1.58	52.36	30.21	1.73
55	\	\	\	\	\	\	\	\	\	41.22	27.86	1.48	43.85	28.49	1.54	50.38	29.86	1.69
60	\	\	\	\	\	\	\	\	\	\	\	\	42.03	30.70	1.37	48.28	32.17	1.50
65	\	\	\	\	\	\	\	\	\	\	\	\	40.53	34.42	1.18	46.56	36.07	1.29
LWT	DB																	
	0			5			7			10			15			20		
	HC	PI	EER	HC	PI	EER	HC	PI	EER	HC	PI	EER	HC	PI	EER	HC	PI	EER
25	70.76	22.54	3.14	74.97	22.72	3.30	83.52	20.12	4.15	83.65	20.82	4.02	96.89	23.18	4.18	100.3	22.78	4.40
30	69.17	23.53	2.94	73.25	23.25	3.15	80.71	20.03	4.03	82.20	21.48	3.83	91.39	22.51	4.06	96.53	22.60	4.27
35	63.51	23.02	2.76	67.39	22.38	3.01	77.00	19.74	3.90	76.86	20.98	3.66	88.16	22.41	3.93	93.40	22.52	4.15
40	64.26	25.60	2.51	68.52	24.13	2.84	75.60	20.54	3.68	77.79	22.93	3.39	85.70	23.48	3.65	87.38	21.95	3.98
45	64.66	28.29	2.29	69.12	25.73	2.69	75.00	22.06	3.40	76.22	23.45	3.25	79.04	23.09	3.42	85.24	23.04	3.70
48	60.57	28.87	2.10	64.75	26.25	2.47	70.26	22.51	3.12	71.40	23.93	2.98	74.04	23.56	3.14	79.85	23.51	3.40
50	59.14	28.74	2.06	63.22	26.14	2.42	68.60	22.41	3.06	69.71	23.83	2.93	72.29	23.46	3.08	77.97	23.41	3.33
55	56.90	28.40	2.00	60.82	25.83	2.35	66.00	22.15	2.98	67.07	23.55	2.85	69.56	23.18	3.00	75.01	23.13	3.24
60	54.53	30.60	1.78	58.29	27.83	2.09	63.25	23.86	2.65	64.28	25.37	2.53	66.66	24.98	2.67	64.70	22.43	2.88
65	52.59	34.31	1.53	56.22	31.20	1.80	61.00	26.75	2.28	55.79	25.60	2.18	57.86	25.21	2.30	47.14	19.00	2.48
LWT	DB																	
	25			30			35			40			43					
	HC	PI	EER	HC	PI	EER	HC	PI	EER	HC	PI	EER	HC	PI	EER			
25	106.2	22.83	4.65	113.6	21.65	5.25	114.4	19.41	5.89	115.9	18.61	6.23	114.3	17.65	6.32			
30	104.7	23.08	4.54	115.4	22.97	5.03	118.6	20.78	5.70	123.3	21.06	5.85	117.1	19.63	5.97			
35	102.5	22.83	4.49	114.2	23.70	4.82	121.5	22.91	5.30	126.2	23.27	5.42	118.6	21.01	5.65			
40	96.13	22.43	4.29	105.7	23.88	4.43	112.5	22.45	5.01	117.9	23.00	5.13	110.3	20.76	5.31			
45	93.44	23.54	3.97	95.43	22.59	4.22	102.8	21.62	4.76	105.4	21.71	4.85	99.25	19.84	5.00			
48	87.53	24.02	3.64	89.40	23.06	3.88	96.32	22.06	4.37	98.74	22.16	4.46	92.98	20.25	4.59			
50	85.47	23.92	3.57	87.28	22.95	3.80	94.04	21.96	4.28	96.40	22.06	4.37	90.78	20.16	4.50			
55	82.23	23.64	3.48	83.98	22.69	3.70	90.48	21.71	4.17	92.75	21.80	4.25	87.34	19.92	4.38			
60	70.93	22.92	3.09	63.58	19.31	3.29	68.51	18.47	3.71	70.23	18.56	3.78	66.13	16.96	3.90			
65	51.68	19.42	2.66	52.78	18.63	2.83	56.87	17.83	3.19	38.58	11.85	3.26	\	\	\			

**Abbreviations:**

HC: Total heating capacity (kW)

PI: Power input (kW)

LWT: Leaving water temperature (°C)

DB: Dry-bulb temperature for outdoor air temperature (°C)

Performance specifications measured with water pump operating at rated water flow rate.

## HMDC-M110T3

LWT	DB																	
	-25			-20			-18			-15			-10			-5		
	HC	PI	EER	HC	PI	EER	HC	PI	EER	HC	PI	EER	HC	PI	EER	HC	PI	EER
25	64.57	28.55	2.26	75.08	27.89	2.69	82.07	27.51	2.98	87.56	28.72	3.05	91.93	28.07	3.27	104.0	31.15	3.34
30	59.04	27.15	2.18	68.65	26.51	2.59	78.05	26.98	2.89	82.39	28.78	2.86	88.07	28.64	3.08	98.71	31.26	3.16
35	59.70	28.93	2.06	69.42	28.25	2.46	74.53	27.01	2.76	78.76	28.45	2.77	83.55	28.10	2.97	94.05	31.07	3.03
40	52.49	30.03	1.75	61.03	29.33	2.08	69.56	28.59	2.43	74.43	28.71	2.59	78.49	28.18	2.79	89.11	31.02	2.87
45	\	\	\	50.54	32.82	1.54	67.03	34.63	1.94	71.31	32.28	2.21	75.37	31.76	2.37	87.00	35.83	2.43
48	\	\	\	40.52	28.34	1.43	64.57	34.72	1.86	69.05	32.52	2.12	73.03	32.02	2.28	84.96	36.41	2.33
50	\	\	\	\	\	\	60.18	33.56	1.79	64.13	31.33	2.05	68.44	31.13	2.20	80.67	35.86	2.25
55	\	\	\	\	\	\	\	\	\	62.50	34.27	1.82	66.56	33.98	1.96	79.73	39.77	2.00
60	\	\	\	\	\	\	\	\	\	\	\	\	64.56	38.32	1.68	77.03	44.68	1.72
65	\	\	\	\	\	\	\	\	\	\	\	\	61.18	40.67	1.50	72.99	47.41	1.54
LWT	DB																	
	0			5			7			10			15			20		
	HC	PI	EER	HC	PI	EER	HC	PI	EER	HC	PI	EER	HC	PI	EER	HC	PI	EER
25	114.7	32.43	3.54	122.5	29.93	4.09	129.0	28.48	4.53	137.8	29.46	4.68	146.2	30.29	4.83	159.8	32.30	4.95
30	108.1	32.73	3.30	115.1	30.18	3.81	122.3	29.08	4.20	134.9	30.74	4.39	144.8	31.66	4.57	153.0	32.85	4.66
35	103.7	32.44	3.20	109.7	31.01	3.54	112.0	27.0	4.15	126.5	29.77	4.25	139.3	31.17	4.47	146.4	32.17	4.55
40	99.45	33.62	2.96	106.1	32.23	3.29	111.7	28.55	3.91	119.5	29.66	4.03	133.6	31.74	4.21	136.2	30.46	4.47
45	97.85	38.43	2.55	105.1	35.08	3.00	110.0	29.9	3.68	113.5	30.45	3.73	119.1	31.53	3.78	124.8	30.39	4.11
48	97.15	39.70	2.45	103.1	35.80	2.88	108.4	30.64	3.54	110.8	30.93	3.58	117.3	32.32	3.63	122.9	31.14	3.95
50	93.53	39.64	2.36	101.9	36.70	2.78	106.6	31.27	3.41	109.6	31.74	3.45	115.4	32.99	3.50	120.9	31.79	3.80
55	92.66	44.08	2.10	100.6	40.66	2.47	106.0	35.3	3.00	107.4	35.11	3.06	114.1	36.62	3.12	119.6	35.28	3.39
60	88.41	48.91	1.81	98.41	46.26	2.13	103.4	40.06	2.58	105.9	40.26	2.63	111.3	41.51	2.68	116.6	40.00	2.92
65	86.26	53.44	1.61	95.37	50.20	1.90	100.0	42.92	2.33	102.5	42.02	2.44	92.36	36.27	2.55	96.79	34.95	2.77
LWT	DB																	
	25			30			35			40			43					
	HC	PI	EER	HC	PI	EER	HC	PI	EER	HC	PI	EER	HC	PI	EER			
25	173.4	34.54	5.02	178.8	34.94	5.12	184.3	34.07	5.41	175.9	27.97	6.29	171.7	26.81	6.40			
30	161.2	34.16	4.72	165.8	32.55	5.09	170.4	31.86	5.35	160.8	26.60	6.04	156.0	25.51	6.12			
35	150.8	32.86	4.59	154.7	30.57	5.06	160.5	30.89	5.20	148.8	26.27	5.66	144.6	25.22	5.73			
40	139.3	30.28	4.60	135.8	27.67	4.91	142.6	28.14	5.07	131.7	25.43	5.18	126.2	23.99	5.26			
45	126.7	29.82	4.25	120.2	27.16	4.43	126.9	28.16	4.51	115.3	24.58	4.69	109.4	23.10	4.74			
48	124.8	30.56	4.08	118.4	27.84	4.25	125.0	28.86	4.33	113.5	26.02	4.36	107.8	24.30	4.43			
50	122.8	31.19	3.94	116.5	28.42	4.10	123.0	29.46	4.18	111.7	26.08	4.28	106.0	24.53	4.32			
55	121.4	34.62	3.51	115.2	31.54	3.65	121.7	32.70	3.72	110.5	29.28	3.77	104.9	27.23	3.85			
60	118.4	39.25	3.02	102.5	31.54	3.25	108.3	32.70	3.31	98.33	28.63	3.43	93.34	26.06	3.58			
65	98.25	34.29	2.87	79.93	25.87	3.09	85.79	27.24	3.15	60.30	18.50	3.26	\	\	\			

**Abbreviations:**

HC: Total heating capacity (kW)

PI: Power input (kW)

LWT: Leaving water temperature (°C)

DB: Dry-bulb temperature for outdoor air temperature (°C)

Performance specifications measured with water pump operating at rated water flow rate.

LWT	DB																	
	-25			-20			-18			-15			-10			-5		
	HC	PI	EER	HC	PI	EER	HC	PI	EER	HC	PI	EER	HC	PI	EER	HC	PI	EER
25	77.13	41.27	1.87	89.69	40.31	2.22	98.04	39.76	2.47	104.6	41.51	2.52	109.8	40.57	2.71	124.3	45.02	2.76
30	70.53	39.24	1.80	82.01	38.32	2.14	93.24	39.00	2.39	98.42	40.14	2.45	105.2	41.39	2.54	117.9	45.18	2.61
35	65.45	39.96	1.64	78.53	40.27	1.95	89.37	40.80	2.19	94.44	41.90	2.25	100.2	42.45	2.36	112.8	46.94	2.40
40	56.92	41.03	1.39	66.18	40.07	1.65	77.11	39.94	1.93	89.69	43.58	2.06	94.57	42.79	2.21	107.4	47.10	2.28
45	\	\	\	67.08	47.20	1.42	75.86	46.25	1.64	86.78	46.35	1.87	91.72	45.61	2.01	105.9	51.45	2.06
48	\	\	\	65.81	48.42	1.36	74.42	48.11	1.55	85.14	48.22	1.77	89.99	47.44	1.90	103.9	53.52	1.94
50	\	\	\	\	\	\	71.81	49.56	1.45	82.15	49.67	1.65	86.82	48.87	1.78	100.2	55.13	1.82
55	\	\	\	\	\	\	\	\	\	78.10	51.00	1.53	82.55	50.19	1.64	95.28	56.61	1.68
60	\	\	\	\	\	\	\	\	\	\	\	\	77.60	49.12	1.58	89.57	55.40	1.62
65	\	\	\	\	\	\	\	\	\	\	\	\	72.07	50.98	1.41	83.18	57.51	1.45
LWT	DB																	
	0			5			7			10			15			20		
	HC	PI	EER	HC	PI	EER	HC	PI	EER	HC	PI	EER	HC	PI	EER	HC	PI	EER
25	137.0	46.87	2.92	146.4	43.27	3.38	158.9	38.26	4.15	169.7	40.46	4.20	180.1	41.91	4.30	185.2	42.58	4.35
30	129.1	47.30	2.73	137.5	43.62	3.15	150.6	38.08	3.95	166.2	41.44	4.01	178.3	43.48	4.10	181.6	43.25	4.20
35	124.4	49.01	2.54	131.5	43.69	3.01	142.0	38.17	3.72	161.7	42.28	3.83	172.0	43.87	3.92	178.5	43.99	4.06
40	119.8	51.04	2.35	127.8	46.27	2.76	141.3	40.08	3.52	158.9	43.84	3.62	166.0	43.56	3.81	168.5	42.65	3.95
45	119.1	55.18	2.16	127.9	50.38	2.54	140.0	44.73	3.13	154.4	47.48	3.25	160.6	45.33	3.54	162.5	44.48	3.65
48	116.8	57.40	2.04	125.5	52.41	2.39	137.4	46.53	2.95	152.4	49.71	3.07	156.1	46.74	3.34	159.5	46.27	3.45
50	112.7	59.13	1.91	121.1	53.98	2.24	132.5	47.93	2.77	146.1	50.88	2.87	152.4	48.69	3.13	153.9	47.67	3.23
55	107.2	60.72	1.76	115.1	55.44	2.08	126.0	49.22	2.56	138.9	52.24	2.66	144.5	49.89	2.90	146.3	48.95	2.99
60	100.8	59.43	1.70	108.2	54.26	1.99	118.5	48.17	2.46	130.6	51.13	2.55	135.7	48.75	2.78	137.5	47.91	2.87
65	93.56	61.69	1.52	100.5	56.32	1.78	110.0	50.00	2.20	109.1	47.77	2.29	112.8	45.32	2.49	114.9	44.75	2.57
LWT	DB																	
	25			30			35			40			43					
	HC	PI	EER	HC	PI	EER	HC	PI	EER	HC	PI	EER	HC	PI	EER			
25	188.6	42.81	4.41	190.3	42.67	4.46	192.5	42.59	4.52	195.5	42.13	4.64	191.5	40.53	4.73			
30	185.7	43.23	4.30	188.6	43.35	4.35	190.3	43.04	4.42	192.5	42.69	4.51	187.7	41.02	4.58			
35	182.7	43.86	4.17	185.6	43.67	4.25	188.0	43.19	4.35	188.5	42.65	4.42	180.5	40.68	4.44			
40	171.6	42.92	4.00	173.7	42.10	4.13	176.0	41.34	4.26	176.6	40.93	4.32	169.5	38.97	4.35			
45	165.6	44.70	3.71	169.0	44.99	3.76	170.7	44.68	3.82	172.7	44.39	3.89	159.6	40.49	3.94			
48	162.5	46.50	3.49	165.8	46.80	3.54	167.5	46.48	3.60	169.4	46.18	3.67	156.6	42.12	3.72			
50	156.8	47.90	3.27	159.9	48.21	3.32	161.6	47.88	3.37	163.5	47.57	3.44	151.1	43.39	3.48			
55	149.1	49.19	3.03	152.1	49.50	3.07	153.6	49.17	3.12	155.4	48.85	3.18	143.6	44.56	3.22			
60	140.1	48.14	2.91	112.9	38.27	2.95	114.1	38.02	3.00	115.4	37.77	3.06	106.7	34.45	3.10			
65	93.70	35.98	2.60	90.28	34.20	2.64	91.20	33.97	2.68	61.06	22.33	2.73	\	\	\			

Abbreviations:

HC: Total heating capacity (kW)

PI: Power input (kW)

LWT: Leaving water temperature (°C)

DB: Dry-bulb temperature for outdoor air temperature (°C)

Performance specifications measured with water pump operating at rated water flow rate.

# Hydronic-H Super



## 4.2 Cooling Capacity Tables

### HMDC-M65T3

LWT	DB																	
	-15			-10			-5			0			5			10		
	CC	PI	EER	CC	PI	EER	CC	PI	EER	CC	PI	EER	CC	PI	EER	CC	PI	EER
0	\	\	\	\	\	\	\	\	\	\	\	\	\	\	\	45.35	10.26	4.42
5	\	\	\	\	\	\	\	\	\	\	\	\	\	\	\	50.22	10.87	4.62
7	\	\	\	\	\	\	\	\	\	\	\	\	\	\	\	53.33	11.42	4.67
10	50.41	7.14	7.06	49.81	7.27	6.85	49.20	7.74	6.36	47.51	8.28	5.74	46.12	8.78	5.25	56.65	11.51	4.92
15	57.64	7.20	8.01	56.96	7.32	7.78	56.15	8.16	6.88	53.59	8.03	6.67	52.72	8.14	6.48	61.52	9.84	6.25
20	63.88	7.89	8.10	63.12	7.95	7.94	62.55	8.48	7.38	61.65	8.64	7.14	59.94	8.51	7.05	71.25	10.25	6.95

LWT	DB																	
	15			20			25			30			35			40		
	CC	PI	EER	CC	PI	EER	CC	PI	EER	CC	PI	EER	CC	PI	EER	CC	PI	EER
0	50.13	12.47	4.02	49.40	12.77	3.87	48.73	13.18	3.70	48.00	15.73	3.05	46.37	17.25	2.69	42.66	17.22	2.48
5	58.24	13.32	4.37	57.13	13.63	4.19	55.00	14.08	3.91	53.62	16.80	3.19	52.34	18.43	2.84	48.15	18.39	2.62
7	62.53	14.27	4.38	61.65	14.46	4.26	60.43	15.11	4.00	58.38	17.06	3.42	57.00	19.00	3.00	51.87	18.89	2.75
10	66.16	14.63	4.52	65.37	14.95	4.37	64.53	15.06	4.29	62.60	17.55	3.57	61.00	19.24	3.17	54.29	18.44	2.94
15	73.04	12.99	5.62	72.24	13.79	5.24	70.63	14.71	4.80	67.99	16.24	4.19	64.16	17.39	3.69	58.21	16.92	3.44
20	84.80	14.13	6.00	84.01	15.19	5.53	82.54	16.48	5.01	81.66	17.87	4.57	78.52	18.05	4.35	68.31	16.65	4.10

LWT	DB								
	43			45			48		
	CC	PI	EER	CC	PI	EER	CC	PI	EER
0	40.34	18.11	2.23	37.10	17.40	2.13	27.36	17.24	1.59
5	46.06	19.57	2.35	41.35	18.35	2.25	28.79	16.60	1.73
7	49.02	19.11	2.57	43.89	18.25	2.40	30.21	15.37	1.97
10	51.24	18.85	2.72	46.36	18.03	2.57	31.11	13.59	2.29
15	48.76	15.07	3.23	41.70	13.72	3.04	31.44	10.96	2.87
20	57.32	15.47	3.70	50.25	14.91	3.37	36.12	11.79	3.06

Abbreviations:

CC: Total cooling capacity (kW)

PI: Power input (kW)

LWT: Leaving water temperature (°C)

DB: Dry-bulb temperature for outdoor air temperature (°C)

Notes: Performance specifications measured with water pump operating at rated water flow rate.

LWT	DB																	
	-15			-10			-5			0			5			10		
	CC	PI	EER	CC	PI	EER	CC	PI	EER	CC	PI	EER	CC	PI	EER	CC	PI	EER
0	\	\	\	\	\	\	\	\	\	\	\	\	\	\	\	52.04	14.50	3.59
5	\	\	\	\	\	\	\	\	\	\	\	\	\	\	\	60.51	15.88	3.81
7	\	\	\	\	\	\	\	\	\	\	\	\	\	\	\	64.30	16.33	3.94
10	62.61	10.17	6.16	61.88	10.34	5.98	60.97	10.96	5.56	58.95	11.74	5.02	57.22	12.47	4.59	68.25	15.84	4.31
15	71.60	10.25	6.99	70.75	10.42	6.79	69.58	11.56	6.02	66.49	11.40	5.83	65.41	11.56	5.66	75.21	13.85	5.43
20	79.35	11.23	7.07	78.41	11.31	6.93	77.52	12.01	6.46	76.49	12.25	6.24	74.37	12.08	6.15	82.54	13.92	5.93

LWT	DB																	
	15			20			25			30			35			40		
	CC	PI	EER	CC	PI	EER	CC	PI	EER	CC	PI	EER	CC	PI	EER	CC	PI	EER
0	61.13	18.90	3.23	60.47	19.26	3.14	59.87	19.97	3.00	59.37	23.80	2.49	56.90	25.99	2.19	45.05	18.83	2.39
5	68.99	18.90	3.65	68.25	19.26	3.54	67.57	19.97	3.38	67.01	23.80	2.82	64.22	25.99	2.47	51.09	20.34	2.51
7	75.51	20.25	3.73	75.08	20.43	3.68	74.24	21.43	3.47	70.76	24.16	2.93	70.00	26.82	2.61	54.77	21.16	2.59
10	82.29	20.75	3.97	81.21	21.11	3.85	79.27	21.36	3.71	77.42	24.85	3.12	74.84	27.14	2.76	57.76	20.98	2.75
15	90.84	18.43	4.93	87.99	19.48	4.52	86.77	20.87	4.16	82.41	23.00	3.58	78.72	24.53	3.21	61.94	19.19	3.23
20	95.92	18.60	5.16	94.49	19.62	4.82	93.54	21.34	4.38	91.62	22.95	3.99	87.45	23.23	3.77	72.34	18.92	3.82

LWT	DB								
	43			45			48		
	CC	PI	EER	CC	PI	EER	CC	PI	EER
0	42.36	19.57	2.16	38.95	18.80	2.07	28.73	18.62	1.54
5	47.90	20.96	2.29	43.00	19.65	2.19	29.94	17.78	1.68
7	50.74	20.28	2.50	45.43	19.37	2.34	31.27	16.31	1.92
10	52.78	19.85	2.66	47.75	18.99	2.51	32.04	14.31	2.24
15	49.98	15.78	3.17	42.74	14.37	2.98	32.22	11.48	2.81
20	57.37	15.84	3.62	50.30	15.26	3.30	36.15	12.07	3.00

Abbreviations:

CC: Total cooling capacity (kW)

PI: Power input (kW)

LWT: Leaving water temperature (°C)

DB: Dry-bulb temperature for outdoor air temperature (°C)

Notes: Performance specifications measured with water pump operating at rated water flow rate.

## HMDC-M110T3

LWT	DB																	
	-15			-10			-5			0			5			10		
	CC	PI	EER	CC	PI	EER	CC	PI	EER	CC	PI	EER	CC	PI	EER	CC	PI	EER
0	\	\	\	\	\	\	\	\	\	\	\	\	\	\	\	77.82	18.98	4.10
5	\	\	\	\	\	\	\	\	\	\	\	\	\	\	\	90.04	20.84	4.32
7	\	\	\	\	\	\	\	\	\	\	\	\	\	\	\	94.88	21.42	4.43
10	88.94	16.30	5.46	88.06	16.63	5.30	86.83	16.70	5.20	85.66	16.93	5.06	84.50	17.18	4.92	97.30	20.61	4.72
15	114.8	18.49	6.21	113.7	18.86	6.03	112.0	18.81	5.95	110.9	18.96	5.85	109.9	19.11	5.75	109.2	19.36	5.64
20	124.2	17.55	7.08	123.0	17.90	6.87	121.6	18.25	6.66	120.3	18.40	6.54	119.1	18.56	6.42	118.7	18.78	6.32

LWT	DB																	
	15			20			25			30			35			40		
	CC	PI	EER	CC	PI	EER	CC	PI	EER	CC	PI	EER	CC	PI	EER	CC	PI	EER
0	89.20	24.70	3.61	88.12	26.17	3.37	87.00	26.64	3.27	82.39	28.91	2.85	80.94	32.37	2.50	70.92	30.60	2.32
5	104.1	26.23	3.97	100.1	27.08	3.70	99.20	27.35	3.63	95.84	30.38	3.15	93.72	34.38	2.73	80.59	32.59	2.47
7	109.5	26.78	4.09	106.8	27.36	3.90	105.5	27.50	3.84	101.7	31.11	3.27	100.0	32.78	3.05	85.94	32.34	2.66
10	110.3	26.43	4.17	108.1	27.07	3.99	107.1	27.79	3.85	105.0	30.90	3.40	103.0	33.11	3.11	92.61	32.57	2.84
15	126.8	26.58	4.77	124.3	27.73	4.48	123.1	28.27	4.36	120.8	32.31	3.74	118.4	32.98	3.59	108.5	34.75	3.12
20	140.7	28.20	4.99	137.9	29.01	4.75	136.6	29.65	4.61	134.0	33.73	3.97	131.4	33.51	3.92	112.7	32.44	3.47

LWT	DB								
	43			45			48		
	CC	PI	EER	CC	PI	EER	CC	PI	EER
0	67.47	31.76	2.12	59.26	29.56	2.00	45.23	26.64	1.70
5	77.46	33.93	2.28	67.34	31.31	2.15	51.63	27.18	1.90
7	82.97	34.50	2.41	71.73	31.34	2.29	52.71	23.93	2.20
10	88.76	34.31	2.59	76.87	30.55	2.52	57.47	24.15	2.38
15	92.62	30.78	3.01	78.88	26.98	2.92	58.57	21.58	2.71
20	91.93	27.70	3.32	80.80	25.53	3.17	52.01	17.70	2.94

Abbreviations:

CC: Total cooling capacity (kW)

PI: Power input (kW)

LWT: Leaving water temperature (°C)

DB: Dry-bulb temperature for outdoor air temperature (°C)

Notes: Performance specifications measured with water pump operating at rated water flow rate.

LWT	DB																	
	-15			-10			-5			0			5			10		
	CC	PI	EER	CC	PI	EER	CC	PI	EER	CC	PI	EER	CC	PI	EER	CC	PI	EER
0	\	\	\	\	\	\	\	\	\	\	\	\	\	\	\	105.2	31.59	3.33
5	\	\	\	\	\	\	\	\	\	\	\	\	\	\	\	120.0	33.68	3.56
7	\	\	\	\	\	\	\	\	\	\	\	\	\	\	\	128.2	34.33	3.73
10	115.5	25.09	4.60	114.4	25.59	4.47	112.8	25.71	4.39	111.3	26.06	4.27	109.7	26.44	4.15	133.3	33.59	3.97
15	135.1	25.78	5.24	133.7	26.29	5.09	131.8	26.23	5.02	130.5	26.43	4.94	129.2	26.65	4.85	138.2	29.10	4.75
20	146.2	24.47	5.97	144.7	24.96	5.80	143.1	25.44	5.62	141.6	25.65	5.52	140.1	25.87	5.41	146.6	27.90	5.25

LWT	DB																	
	15			20			25			30			35			40		
	CC	PI	EER	CC	PI	EER	CC	PI	EER	CC	PI	EER	CC	PI	EER	CC	PI	EER
0	117.4	38.02	3.09	111.5	38.75	2.88	110.1	40.47	2.72	108.4	44.51	2.44	106.5	47.14	2.26	74.89	33.46	2.24
5	135.2	40.36	3.35	128.4	41.14	3.12	125.6	43.28	2.90	124.5	46.75	2.66	121.7	49.48	2.46	85.51	36.05	2.37
7	142.2	41.22	3.45	136.9	41.56	3.29	133.5	45.26	2.95	132.1	47.87	2.76	130.0	50.00	2.60	90.76	36.22	2.51
10	146.5	41.62	3.52	144.0	42.74	3.37	142.1	44.20	3.22	138.8	44.40	3.13	135.6	45.06	3.01	98.53	37.06	2.66
15	155.0	37.58	4.13	151.0	39.47	3.83	148.3	40.58	3.65	144.6	40.56	3.56	137.5	39.84	3.45	115.5	39.42	2.93
20	156.3	35.10	4.45	152.9	37.02	4.13	150.2	37.08	4.05	146.6	36.77	3.99	145.6	37.24	3.91	119.4	36.86	3.24

LWT	DB								
	43			45			48		
	CC	PI	EER	CC	PI	EER	CC	PI	EER
0	71.25	34.73	2.05	62.58	32.32	1.94	47.76	29.13	1.64
5	82.19	37.54	2.19	71.45	34.64	2.06	54.78	30.07	1.82
7	87.62	38.63	2.27	75.74	35.10	2.16	55.66	26.80	2.08
10	94.44	39.04	2.42	81.79	34.77	2.35	61.15	27.48	2.23
15	98.55	34.91	2.82	83.93	30.61	2.74	62.32	24.48	2.55
20	97.35	31.47	3.09	85.56	29.00	2.95	55.08	20.12	2.74

Abbreviations:

CC: Total cooling capacity (kW)

PI: Power input (kW)

LWT: Leaving water temperature (°C)

DB: Dry-bulb temperature for outdoor air temperature (°C)

Notes: Performance specifications measured with water pump operating at rated water flow rate.

## 5 Performance Adjustment Factors

### 5.1 Ethylene and Propylene Glycol factors

The antifreeze must be required according to anyone condition as following:

- The ambient temperature is below 0 °C,
- The outlet water temperature is lower than 5 °C,
- Don't start up the unit for a long time,
- The power supply was cut off and needn't change the water in system.

A glycol solution is required when the unit with condition as mentioned. The use of glycol will reduce the performance of the unit depending on concentration.

Concentration of ethylene glycol (%)	Modification coefficient				Freezing point (°C)
	Cooling capacity	Power input	Water resistance	Water flow	
0	1.000	1.000	1.000	1.000	0
10	0.984	0.998	1.118	1.019	-4
20	0.973	0.995	1.268	1.051	-9
30	0.965	0.992	1.482	1.092	-16
40	0.960	0.989	1.791	1.145	-23
50	0.950	0.983	2.100	1.200	-37

Concentration of propylene glycol (%)	Modification coefficient				Freezing point (°C)
	Cooling capacity	Power input	Water resistance	Water flow	
0	1.000	1.000	1.000	1.000	0
10	0.976	0.996	1.071	1.00	-3
20	0.961	0.992	1.189	1.016	-7
30	0.948	0.988	1.380	1.034	-13
40	0.938	0.984	1.728	1.078	-22
50	0.925	0.975	2.150	1.125	-35

### 5.2 Evaporator temperature drop factors

Performance tables are based on a 5°C temperature drop through the evaporator. Temperature drops outside this range can affect the control system's capability to maintain acceptable control and are not recommended.

### 5.3 Altitude correction factors

Performance tables are based at sea level. Elevations other than sea level affect the performance of the unit. The decreased air density will reduce condenser capacity and reduce the unit's performance. Maximum allowable altitude is 1800meters.

### 5.4 Fouling factor

Fouling refers to the accumulation of unwanted material on solid surfaces, most often in an aquatic environment. The fouling material can consist of either living organisms (biofouling) or a non-living substance (inorganic or organic). Fouling is usually distinguished from other surface-growth phenomena in that it occurs on a surface of a component, system or plant performing a defined and useful function, and that the fouling process impedes or interferes with this function.

Other terms used in the literature to describe fouling include: deposit formation, encrustation, crudding, deposition, scaling,

scale formation, slagging, and sludge formation. The last six terms have a more narrow meaning than fouling within the scope of the fouling science and technology, and they also have meanings outside of this scope; therefore, they should be used with caution.

Fouling phenomena are common and diverse, ranging from fouling of ship hulls, natural surfaces in the marine environment (marine fouling), fouling of heat-transfer components through ingredients contained in the cooling water or gases, and even the development of plaque or calculus on teeth, or deposits on solar panels on Mars, among other examples.

Foreign matter in the chilled water system will adversely affect the heat transfer capability of the evaporator, and could increase the pressure drop and reduce the water flow. To provide optimum unit operation, proper water treatment must be maintained. Refer to the table as following.

ALTITUDE (m)	Difference of water inlet and outlet temp. (°C)	Fouling Factor							
		0.018 m <sup>2</sup> . °C /kW		0.044 m <sup>2</sup> . °C /kW		0.086 m <sup>2</sup> . °C /kW		0.172 m <sup>2</sup> . °C /kW	
		C	P	C	P	C	P	C	P
Sea level	3	1.036	1.077	1.019	1.076	0.991	0.975	0.963	0.983
	4	1.039	1.101	1.022	1.080	0.994	0.996	0.971	0.984
	5	1.045	1.105	1.028	1.086	1.000	1.000	0.977	0.989
	6	1.051	1.109	1.034	1.093	1.006	1.004	0.983	0.994
600	3	1.024	1.087	1.008	1.064	0.980	0.984	0.951	0.991
	4	1.027	1.111	1.011	1.068	0.983	1.005	0.959	0.992
	5	1.034	1.115	1.017	1.074	0.989	1.009	0.965	0.997
	6	1.043	1.115	1.026	1.084	0.998	1.009	0.973	0.999
1200	3	1.013	1.117	0.996	1.052	0.969	1.011	0.942	1.002
	4	1.015	1.118	0.998	1.055	0.971	1.012	0.948	1.003
	5	1.023	1.122	1.006	1.063	0.979	1.015	0.955	1.005
	6	1.031	1.125	1.015	1.072	0.987	1.018	0.962	1.007
1800	3	1.002	1.128	0.986	1.042	0.959	1.021	0.935	1.007
	4	1.005	1.129	0.989	1.045	0.962	1.022	0.941	1.010
	5	1.012	1.132	0.995	1.051	0.968	1.024	0.945	1.012
	6	1.018	1.134	1.001	1.058	0.974	1.026	0.949	1.014

Abbreviations:

C: Cooling capacity

P: Power input

6 Hydronic Performance

HMDC-M65T3 / HMDC-M75T3

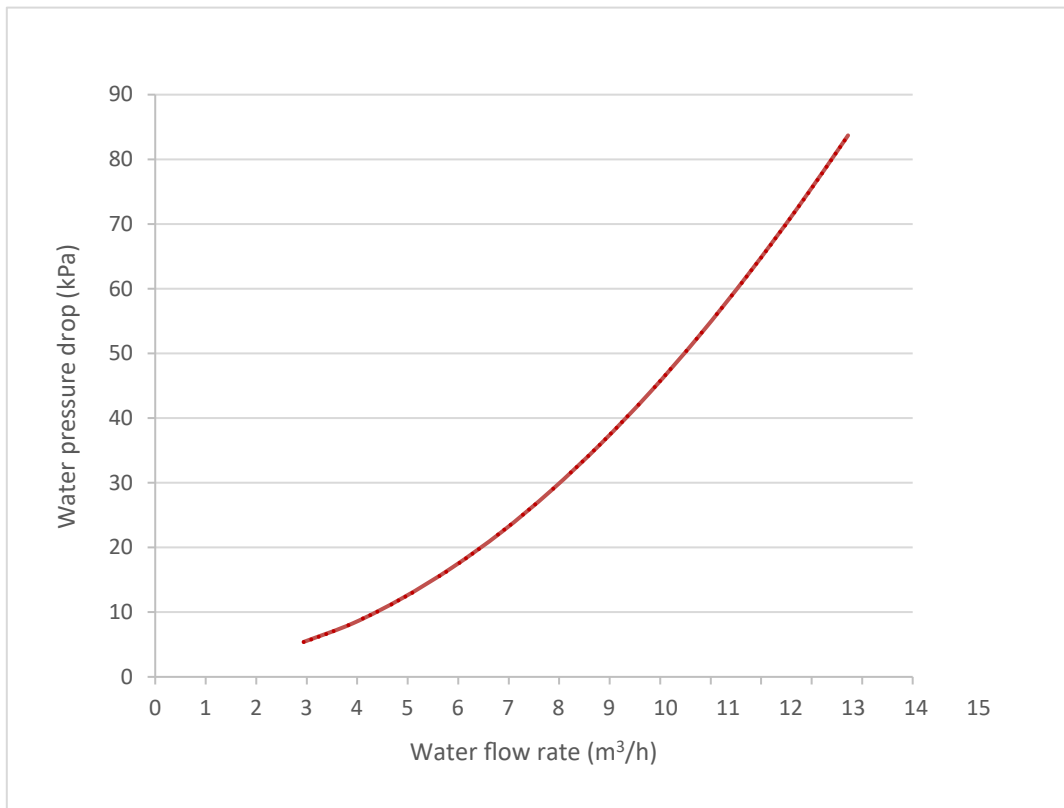

HMDC-M110T3 / HMDC-M140T3

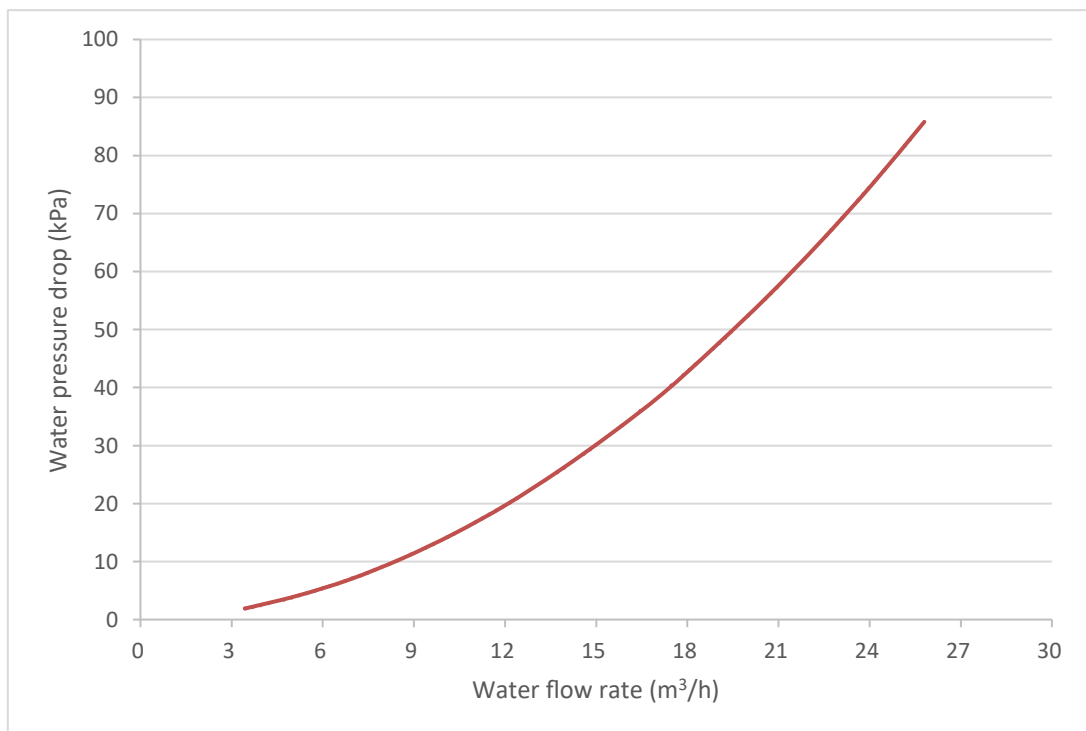

**7 Octave Band Levels**

For 65/75kW

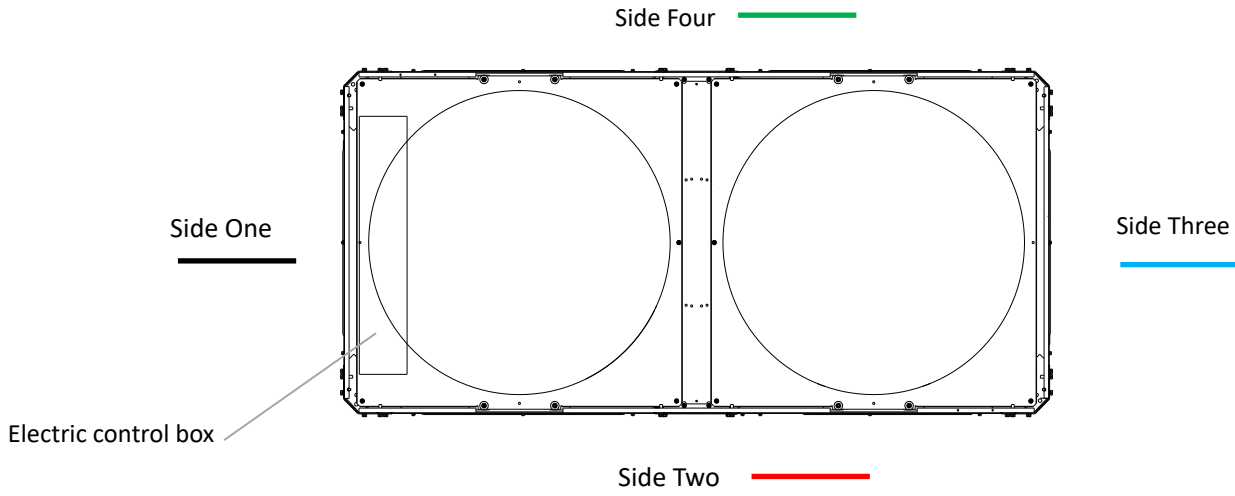

Test condition: Outdoor ambient temperature 35°C DB. EWT 12°C, LWT 7°C

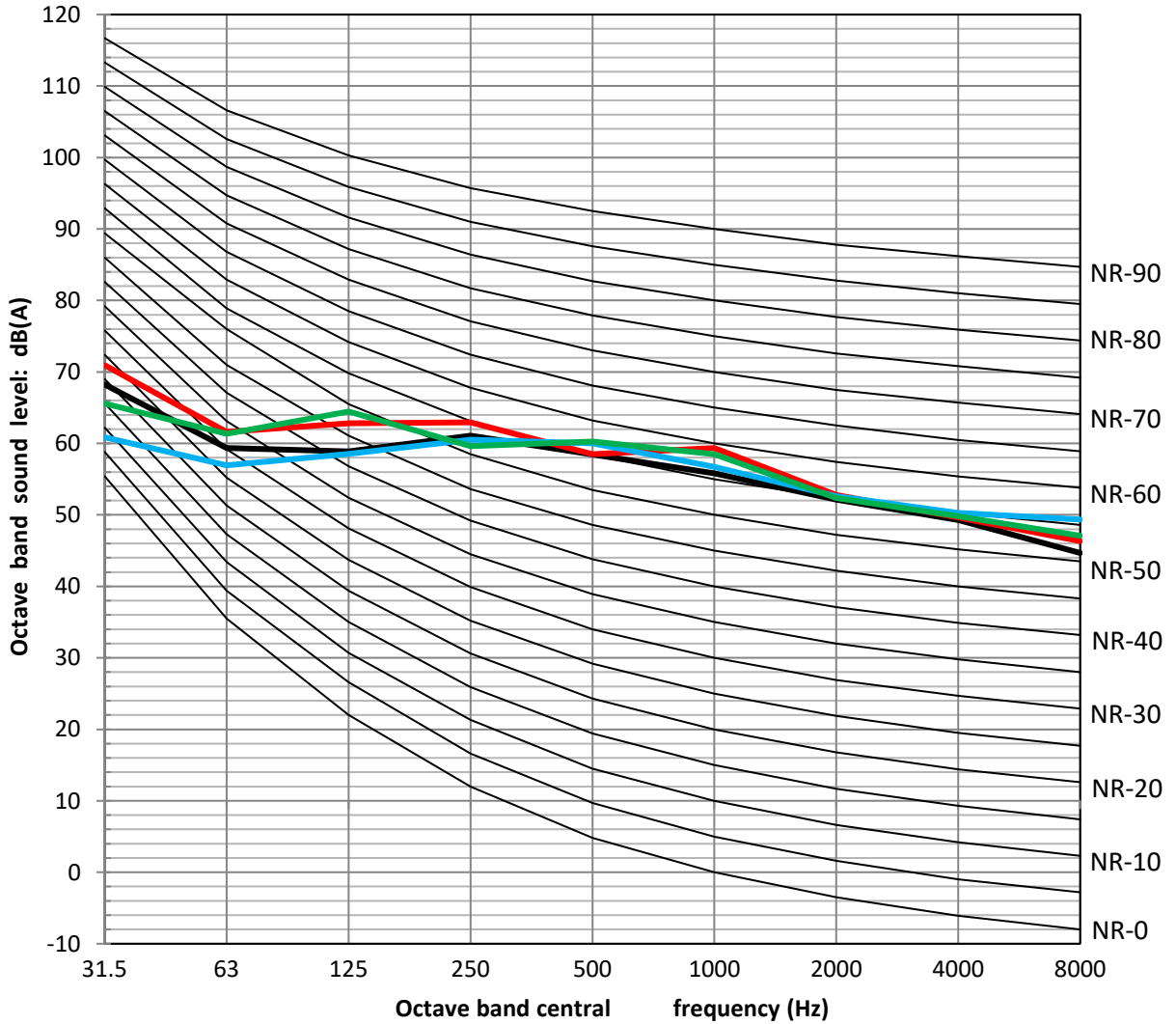

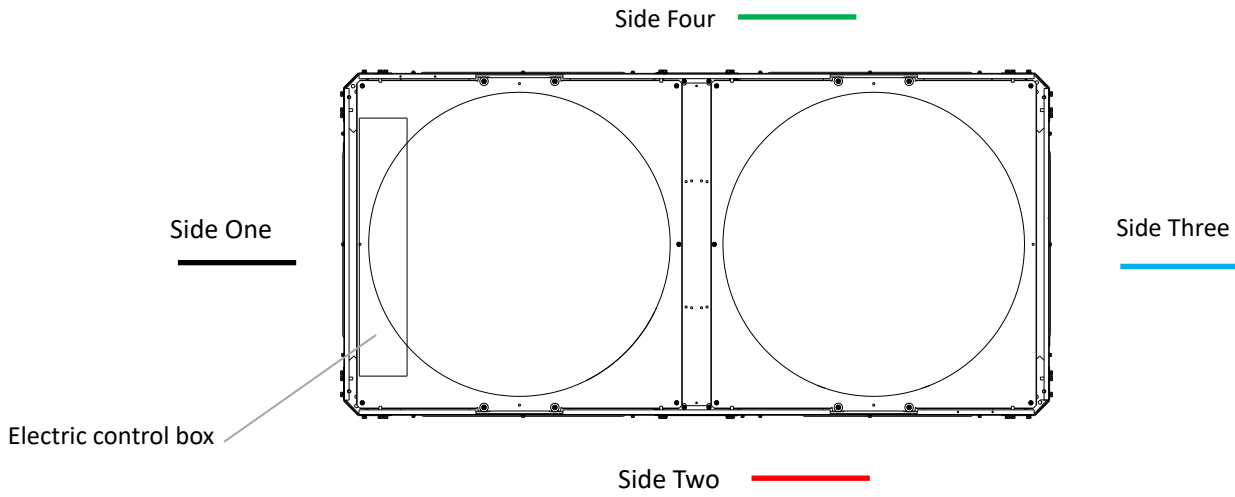

Test condition: Outdoor ambient temperature 35°C DB. EWT 12°C, LWT 7°C

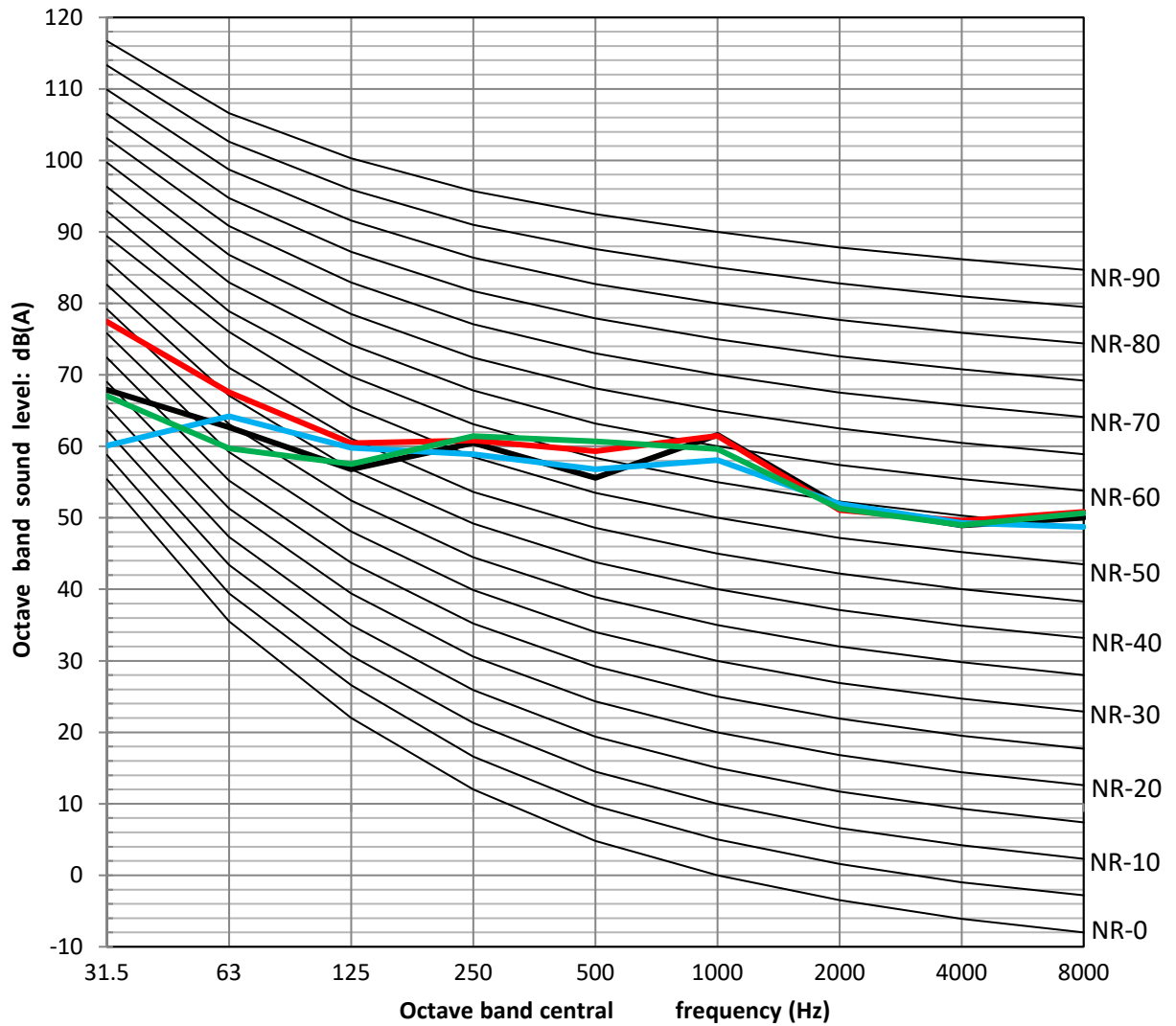

# Part 3

# User Interface Field Settings

<b>1 Introduction</b>	<b>33</b>
<b>2 Service menu</b>	<b>35</b>
<b>3 Project menu</b>	<b>42</b>
<b>4 Parameters setting</b>	<b>46</b>

## 1 Introduction

During installation, the unit's settings and parameters should be configured by the installer to suit the installation configuration, climate conditions and end-user preferences. The relevant settings are accessible and programmable through the SERVICE and PROJECT menu on the wired controller's user interface.

KJRM-120H2/BMWKO-E

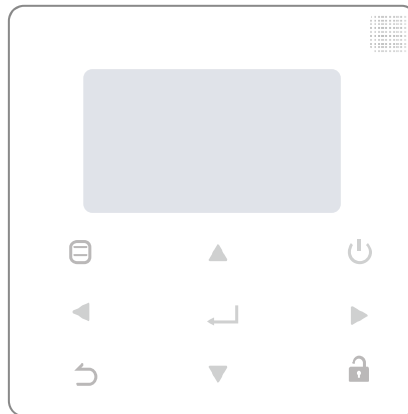

Icon	Function
	Enter the menu structure from the home page
	Navigate the cursor on the display/navigate in the menu structure/ adjust the settings
	Turn on or off the space operation mode
	Come back to the up level
	Long press for unlocking /locking the controller
	Go to the next step when programming a schedule in the menu structure / confirm a selection/enter a submenu in the menu structure

## 2 Service menu

### 2.1 Structure

**For SERVICE Menu**

1. STATE QUERY
2. CLEAR HSITORY ERRORS
3. SETTING ADDRESS
4. HEAT CONTROL
5. TEMPERATURE COMPENSATION
6. PUMP CONTROL
7. MANUAL DEFROST
8. LOW OUTLET WATER CONTROL
9. VACUUM SWITCH
10. ENERGY SAVING SWITCH
11. DHW ENABLE
12. FACTORY DATA RESET

**1. STATE QUERY**

**2. CLEAR HISTORY ERRORS**

- CLEAR UNIT HISTORY ERRORS
- CLEAR ALL HISTORY ERRORS
- CLEAR LOCK ERRORR
- CLEAR RUN TIME

**3. SETTING ADDRESS**

- CONTROLLER ADDRESS
- CONTROL ENABEL
- MODBUS ENABLE
- MODBUS ADDRESS

**4. HEAT CONTROL**

- HEAT1
- HEAT2
- FORCED HEAT2 OPEN

**5. TEMPERATURE COMPENSATION**

- COOL MODE ENABLE
- T4\_COOL\_1
- T4\_COOL\_2
- OFFSET-C
- HEAT MODE ENABLE
- T4\_HEAT\_1
- T4\_HEAT\_2

**6. PUMP CONTROL**

- FORCED PUMP OPEN
- INV PUMP SETTING
- PUMP ON/OFF TIME

**7. MANUAL DEFROST**

**8. LOW OUTLETWATER CONTROL**

**9. VACUUM SWITCH**

**10. ENERGY SAVING SWITCH**

**11. DHW ENABLE**

**12. FACTORY DATA RESET**

## 2.2 Service Menu

### MENU > Service Menu

Service Menu allows installers to input the system configuration and set the system parameters. Enter the password, using ◀ ▶ to navigate between digits and using ▼ ▲ to adjust the numerical values, and then press ↵. The password is 234.

SERVICE MENU
PLEASE INPUT THE PASSWORD
0 0 0
OK
▼ ▲

The following pages will be displayed after putting the password.

SERVICE MENU
STATE QUERY
CLEAR HISTORY ERRORS
SETTING ADDRESS
HEAT CONTROL
OK
1/3
▼ ▲

SERVICE MENU
TEMPERATURE COMPENSATION
PUMP CONTROL
MANUAL DEFROST
LOW OUTLET WATER CONTROL
OK
2/3
▼ ▲

SERVICE MENU
VACUUM SWITCH
ENERGY SAVING SWITCH
DHW ENABLE
FACTORY DATA RESET
OK
3/3
▼ ▲

## 2.3 State query

### MENU > Service Menu > State query

SERVICE MENU
STATE QUERY
CLEAR HISTORY ERRORS
SETTING ADDRESS
HEAT CONTROL
OK
1/3
▼ ▲

STATE QUERY allows installers to check the operation parameters. Press ◀ ▶ to select the address of units.

STATE QUERY	
SELECT ADDRESS	◀ 07 ▶ #
ODU MODEL	130 kW
COMP FREQUENCY	50 Hz
COMP1 CURRENT	20 A
COMP2 CURRENT	20 A
BACK	
▼ ▲	

STATE QUERY	
H-P PRESSURE	3.83 MPa
L-P PRESSURE	1.00 MPa
TP1 DISCHARGE TEMP	30 °C
TP2 DISCHARGE TEMP	30 °C
TH SUCTION TEMP	-20 °C
OK	
2/9	
▼ ▲	

STATE QUERY	
TZ TEMP	-20°C
T3 TEMP	-20°C
T4 TEMP	-20°C
T6A TEMP	40°C
T6B TEMP	40°C
BACK	
3/9	
▼ ▲	

STATE QUERY	
TFIN1 TEMP	60 °C
TFIN2 TEMP	60 °C
TDSH	30 °C
TSSH	15 °C
TCSH	15 °C
BACK	
4/9	
▼ ▲	

STATE QUERY	
FAN1 SPEED	850 RPM
FAN2 SPEED	850 RPM
FAN3 SPEED	850 RPM
EXV A	1800 P
EXV B	1800 P
BACK	
5/9	
▼ ▲	

STATE QUERY	
EXV C	1800P
Tw1 TEMP	30°C
Two TEMP	30°C
Tw TEMP	30°C
TAF1 TEMP	30°C
BACK	
6/9	
▼ ▲	

STATE QUERY	
TAF2 TEMP	30 °C
T5 TEMP	30 °C
COMP TIME1	120 MIN
COMP TIME2	120 MIN
COMP TIME3	120 MIN
BACK	7/9

STATE QUERY	
COMP TIME	65535 H
FIX PUMP TIME	65535 H
INV PUMP TIME	65535 H
ODU SOFTWARE	V45
HMI SOFTWARE	V45
BACK	8/9

STATE QUERY	
DEFROSTING STATE	
00	01
02	03
04	05
06	07
08	09
10	11
12	13
14	15
E2 SOFTWARE V45	
END	
OK	9/9

Note:

1. Tzplate heat exchanger outlet temperature

T3 lowest temperature of condenser tube

T4 ambient temperature

T6A, T6B EVI plate heat exchanger refrigerant temperature

Tfin1, Tfin2 inverter module temperature

TDSH Discharge superheat temperature

TSSH Suction superheat temperature

TCSH Injection superheat temperature

Twi Unit water inlet temperature

Two Unit water outlet temperature

Tw Total water outlet temperature

Taf1 DHW water pipe antifreeze temperature

Taf2 Water side antifreeze temperature

T5 Water tank temperature

2. For ODU SOFTWARE and HMI SOFTWARE, the version number will vary with product iterations.

## 2.4 Clear history errors

MENU > Service Menu > Clear history errors

SERVICE MENU	
STATE QUERY	
CLEAR HISTORY ERROR	
SETTING ADDRESS	
HEAT CONTROL	
OK	1/3

CLEAR HISTORY ERRORS	
CLEAR UNIT HISTORY ERRORS	
CLEAR ALL HISTORY ERRORS	
CLEAR LOCK ERROR	
CLEAR RUN TIME	
OK	

**CLEAR HISTORY ERRORS** is used to clear the history error codes and component operation time.

CLEAR UNIT HIS ERRS	
SELECT ADDRESS	◀ 07 ▶
DO YOU WANT TO CLEAR?	◀ YES ▶
OK	

CLEAR ALL HIS ERRS	
DO YOU WANT TO CLEAR?	◀ YES ▶
OK	

CLEAR LOCK ERR	
DO YOU WANT TO CLEAR?	◀ YES ▶
OK	



CLEAR RUN TIME	
SELECT ADDRESS	◀ 07 ▶
CLEAR COMP TIME?	◀ NO ▶
CLEAR FIX PUMP TIME?	◀ NO ▶
CLEAR INV PUMP TIME?	◀ NO ▶
OK	



## Hydronic-H Super

### 2.5 Setting address

MENU > Service Menu > Setting address

SERVICE MENU
STATE QUERY
CLEAR HISTORY ERROR
<b>SETTING ADDRESS</b>
HEAT CONTROL
OK 1/3

**SETTING ADDRESS** is used to set whether the unit can be controlled by wired controller and through MDOBUS. SETTING ADDRESS can also enter by combining buttons pressing  ,  for 3s.

CONTROLLER ADDRESS	◀ 10 ▶ #
CONTROL ENABEL	◀ NO ▶
MODBUS ENABLE	◀ NO ▶
MODBUS ADDRESS	◀ 10 ▶ #
OK	 

**CONTROLLER ADDRESS** selects the unit address then we can check the parameters about this unit.

If CONTROL ENABLE sets as YES, it means the controller can set all the parameters; if CONTROL ENABLE sets as NO, it means the controller can only display the parameters.

If the chiller system access to MODBUS system, MODBUS ENABLE should be set as YES. Please note that in this case, **CONTROL ENABLE** should be also set as YES, otherwise the units cannot be controlled.

**MODBUS ADDRESS** set the controller address if the Modbus system is available.

### 2.6 Heat control



MENU > Service Menu > Heat control



SERVICE MENU
STATE QUERY
CLEAR HISTORY ERROR
SETTING ADDRESS
<b>HEAT CONTROL</b>
OK 1/3

HEAT CONTROL
HEAT1
HEAT2
FORCED HEAT2 OPEN
OK

**HEAT1** means pipe electric heating in heating mode.

**HEAT2** means tank electric heating in DHW mode.

HEAT1	
HEAT1 ENABLE	◀ NO ▶
TEMP-AUXHEAT1-ON	◀ 07 ▶ °C
TW. HEAT1-ON	◀ 25 ▶ °C
TW. HEAT1-OFF	◀ 45 ▶ °C
OK 1/2	 

HEAT2	
ALL HEAT2 DISABLE	◀ YES ▶
SELECT ADDRESS	◀ 10 ▶ #
HEAT2-ENABLE	◀ NO ▶
T-HEAT2-DELAY	◀ 190 ▶ MIN
DT5-HEAT2-OFF	◀ 10 ▶ °C
OK 1/2	 

HEAT2							
T4-HEAT2-ON	◀ 10 ▶ °C						
00	01	02	03	04	05	06	07
08	09	10	11	12	13	14	15
OK	2/2	↕ ↔					

FORCED HEAT2 OPEN							
SELECTED ADDRESS	◀ 10 ▶						
FORCED HEAT2 OPEN	◀ NO ▶						
00	01	02	03	04	05	06	07
08	09	10	11	12	13	14	15
OK		↕ ↔					

**TEMP-AUXHEAT1-ON** sets the ambient temperature below which the pipe heater (field supplied) turns on. When the leaving water temperature reaches TW. HEAT1-ON, the pipe electric heater (field supplied) turns on automatically. When the leaving water temperature reaches TW. HEAT1-OFF, the pipe electric heater (field supplied) turns off automatically. If the system is installed with tank booster heater, ALL HEAT2 DISABLE should be set as YES.

**HEAT2-ENABLE** sets the state of tank booster heater of SELECT ADDRESS.

**T-HEAT2-DELAY** sets the delay time for tank booster heater to turn on after the compressor starts.

**DT5-HEAT2-OFF** sets the temperature difference between the actual water temperature and setting temperature above which the tank booster heater turns off.

**T4\_HEAT2\_ON** sets the ambient temperature that tank booster heater turns on. (00~15 means unit address)

If **FORCED HEAT2 OPEN** is set as YES, when  $T5 < T5-1$ , then tank electric heater turns on; when  $T5 \geq T5$ , then tank electric heater off. (00~15 means unit address)

## 2.7 Temperature Compensation

MENU > Service Menu > Temperature Compensation

SERVICE MENU		
TEMPERATURE COMPENSATION		
PUMP CONTROL		
MANUAL DEFROST		
LOW OUTLET WATER CONTROL		
OK	2/3	↕

With the help of **TEMPERATURE COMPENSATION**, water temperature will automatically change as outside air temperature changes. When outdoor air temperature increases/decreases, the heating load will decrease/increase and water temperature will decrease/increase automatically. When outdoor air temperature decreases/increases, the cooling load will decrease/increase and water temperature will increase/decrease automatically.

TEMP COMPENSATION		
COOL MODE ENABLE	◀ YES ▶ °C	
T4 COOL-1	◀ 15 ▶ °C	
T4 COOL-2	◀ 08 ▶ °C	
OFFSET-C	◀ 10 ▶ °C	
OK	1/2	↕ ↔

TEMP COMPENSATION		
HEAT MODE ENABLE	◀ YES ▶ °C	
T4 HEAT-1	◀ 08 ▶ °C	
T4 HEAT-2	◀ 15 ▶ °C	
OFFSET-H	◀ 10 ▶ °C	
OK	2/2	↕ ↔

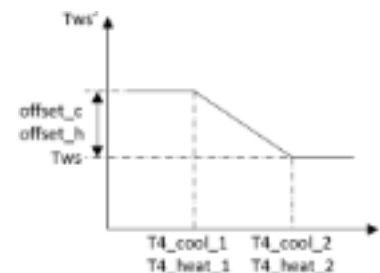

**T4 COOL-1, T4 COOL-2** set the ambient temperature for cooling mode.

**T4 HEAT-1, T4 HEAT-2** set the ambient temperature for heating mode.

**Offset\_c, Offset\_h** is the temperature difference between current water temperature and T4\_cool\_1, T4\_heat\_1 corresponding water temperature.

## 2.8 Pump Control

MENU > Service Menu > Pump Control

SERVICE MENU
TEMPERATURE COMPENSATION
<b>PUMP CONTROL</b>
MANUAL DEFROST
LOW OUTLET WATER CONTROL
OK 2/3

PUMP CONTROL
FORCED PUMP OPEN
INV PUMP SETTING
PUMP ON/OFF TIME
OK

FORCED PUMP OPEN
SELECT ADDRESS ◀ 0 ▶ #
FORCED PUMP OPEN ◀ NO ▶
OK

INV PUMP SETTING
SELECT ADDRESS ◀ 07 ▶ #
SWITCH ON THE PUMP ◀ NO ▶
RATIO PUMP ◀ 100 ▶ #
OK

PUMP ON/OFF TIME
PUMP ON TIME ◀ 05 ▶ MI
PUMP OFF TIME ◀ 05 ▶ MI
OK

**FORCED PUMP OPEN** is used to control the fixed frequency pump (field supplied) operation.

**INV PUMP SETTING** is used to control the inverter water pump (field supplied) operation, the setting range of RATIO-PUMP is 30%-100%. It should ensure its flow meet the requirement of whole unit, otherwise the unit may be damaged.

**PUMP ON TIME** sets the pump operation time after the unit stops.

If PUMP OFF TIME sets as 0, the pump will run all the time. Otherwise, the pump will operate intermittently according to the PUMP ON TIME and PUMP OFF TIME setting.

	Set range	Default value	Adjustment range
PUMP ON TIME	5~60min	5	5
PUMP OFF TIME	0~60min	0	5

## 2.9 Manual Defrost

MENU > Service Menu > Manual Defrost

SERVICE MENU
TEMPERATURE COMPENSATION
PUMP CONTROL
<b>MANUAL DEFROST</b>
LOW OUTLET WATER CONTROL
OK 2/3

MANUAL DEFROST
SELECT ADDRESS ◀ 07 ▶ #
MANUAL DEFROST ◀ NO ▶
OK

**MANUAL DEFROST** can force the unit to enter the defrost mode manually.

If the external unit successfully enters the defrost mode after the "MANUAL DEFROST" is turned on, the defrost icon  will be displayed at homepage of the wired controller.

## 2.10 Low outlet water temperature control

MENU > Service Menu > Low outlet water temperature control

SERVICE MENU
TEMPERATURE COMPENSATION
PUMP CONTROL
MANUAL DEFROST
<b>LOW OUTLET WATER CONTROL</b>
OK 2/3

At this page, the historical minimum water outlet temperature setting (setting range 0-20°C) can be viewed.

LOW OUTLET WATER CTRL	
MIN TEMP FOR COOL	◀ 50°C ▶
HISTORICAL SETTING	
04/06/2020 11:30A	5°C
04/06/2020 11:30A	5°C
04/06/2020 11:30A	5°C
OK	

**MIN TEMP FOR COOL** sets the lowest water temperature for cooling mode. Please notice that When the setting temperature is less than 5°C, antifreeze liquid should be added in the water system.

LOW OUTLET WATER CONTROL
The setting temp is below 5 degree please confirm whether it is an antifreeze system?
OK

## 2.11 Vacuum switch

MENU > Service Menu > Vacuum switch

SERVICE MENU
<b>VACUUM SWITCH</b>
ENERGY SAVING SWITCH
DHW ENABLE
FACTORY DATA RESET
OK 3/3

VACUUM SWITCH	
VACUUM SWITCH	◀ NO ▶
OK	

**VACUUM SWITCH** is used for vacuuming.

## 2.12 Energy saving mode

MENU > Service Menu > Energy saving mode

SERVICE MENU
VACUUM SWITCH
<b>ENERGY SAVING SWITCH</b>
DHW ENABLE
FACTORY DATA RESET
OK 3/3

ENERGY SAVING SWITCH	
SAVING SWITCH	◀ 80% ▶
HISTORICAL SETTING	
04/06/2020 11:30A	80%
04/06/2020 11:30A	80%
04/06/2020 11:30A	80%
OK	

For projects with temporary electricity supply restrictions, the outdoor unit supports 7 levels of energy management which can be set to output 40-100% capacity. It prevents tripping during electricity supply restriction conditions and remains system continue to operate. The historical energy saving switch setting can be viewed.

## 2.13 DHW ENABLE

MENU > Service Menu > DHW ENABLE

Domestic hot water function can be customized.

DHW ENABLE	
DHW ENABLE	◀ NO ▶
OK	

## 2.14 Factory data reset

MENU > Service Menu > Factory data reset

Factory data reset is used to reset all the data to the factory default setting.

FACTORY DATA RESET	
DO YOU WANT TO RESET?	◀ YES ▶
OK	

**3 Project meun**

**3.1 Structure**

- For PROJECT Menu**
1. SET UNIT-AIRCONDITIONING
  2. SET PARALLEL UNIT
  3. SET UNIT PROTECTION
  4. SET DEFROSTING
  5. SET DHW TIME
  6. SET E9 TIME
  7. INV PUMP RATIO
  8. CHECK PARTS

- 1. SET UNIT-AIRCONDITIONING**
- TWO\_COOL\_DIFF
  - TWO\_HEAT\_DIFF
  - DT5\_ON
  - DTIS5
  - DtTws

- 2. SET PARALLEL UNIT**
- TIM\_CAP\_ADJ
  - TW\_COOL\_DIFF
  - TW\_HEAT\_DIF
  - RATIO\_COOL\_FIRST
  - RATIO\_HEAT\_FIRST

- 3. SET UNIT PROTECTION**
- T\_DIFF\_PRO
  - TWI\_O\_ABNORMAL

- 4. SET DEFROSTING**
- T\_FROST
  - T\_DEFROST\_IN
  - T\_DEFROST\_OUT

- 5. SET DHW TIME**
- SELECT ADDRESS
  - COOL MIN TIME 0.5h
  - COOL MAX TIME
  - HEAT MIN TIME
  - HEAT MAX TIME
  - DHW MIN TIME
  - DHW MAX TIME

- 6. SET E9 TIME**
- E9 PROTECT TIME
  - E9 DETECTION METHOD

- 7. INV PUMP RATIO**
- MIN RATIO
  - MAX RATIO

- 8. INV PUMP RATIO**
- MIN RATIO
  - MAX RATIO

## 3.2 Project Menu

### MENU > Project Menu

Project Menu allows installers to input the system configuration and set the system parameters. Enter the password, using ◀ ▶ to navigate between digits and using ▼ ▲ to adjust the numerical values, and then press **OK**. The password is 9877.

PROJECT MENU	
PLEASE INPUT THE PASSWORD	
0 0 0 0	
OK	▼ ▲

The following pages will be displayed after putting the password.

PROJECT MENU	
SET UNIT AIRCONDITIONING	
SET PARALLEL UNIT	
SET UNIT PROTECTION	
SET DEFROSTING	
OK	1/2 ▼

PROJECT MENU	
SET DHW TIME	
SET E9 TIME	
INV PUMP RATIO	
CHECK PARTS	
OK	2/2 ▼

## 3.3 SET UNIT-AIRCONDITIONING

### MENU > Project Menu > SET UNIT-AIRCONDITIONING

SET UNIT	
TWO_COOL_DIFF	◀ 2 ▶ °C
TWO_HEAT_DIFF	◀ 2 ▶ °C
DT5_ON	◀ 8 ▶ °C
DTIS5	◀ 10 ▶ °C
DtTws	◀ 1 ▶ °C
OK	▼ ▲

**TWO\_COOL\_DIFF** sets the minimum temperature difference between the leaving water temperature (Two) and the leaving water set temperature (TwoS) above which the unit will start for cooling mode. When  $Two - TwoS \geq TWO\_COOL\_DIFF$ , unit starts. When  $TwoS - Two \geq 2$  lasts for 5s, unit stops.

**TWO\_HEAT\_DIFF** sets the minimum temperature difference between the leaving water temperature (Two) and the leaving water set temperature (TwoS) above which the unit will start for heating mode. When  $TwoS - Two \geq TWO\_HEAT\_DIFF$ , unit starts. When  $Two - TwoS \geq 2$  lasts for 5s, unit stops.

If unit is customized with the DHW function, when  $TempW\_heat\_Min\_n \leq T5 < \min(T5S, TempW\_heat\_Max\_n) - dt5\_ON$  and  $Two < \min(T5S, TempW\_heat\_Max\_n) - 2$ , then DHW mode is on.

Note:

The value of  $TempW\_heat\_Min\_n$ ,  $T5S$ ,  $TempW\_heat\_Max\_n$  are related to the ambient temperature, which are already fixed in the program.

$T5$  means the water tank temperature

$T5S$  means the setting temperature of DHW mode

The target leaving water temperature of DHW mode is  $Twos = T5S + DT1S5$ . If  $Two > TempW\_heat\_Max\_n$ , then DHW mode is off.

**DtTws** is reserved.

### 3.4 SET PARALLEL UNIT

MENU > Project Menu > SET PARALLEL UNIT

SET PAPALLEL UNIT	
TIM_CAP_ADJ	◀ 180 ▶ S
TW_COOL_DIFF	◀ 2 ▶ °C
TW_HEAT_DIFF	◀ 2 ▶ °C
RATIO_COOL_FIRST	◀ 0 ▶ %
RATIO_HEAT_FIRST	◀ 50 ▶ %
<div style="display: flex; justify-content: space-between; align-items: center;"> <span>OK</span> <span>↕ ▶</span> </div>	

**TIM\_CAP\_ADJ** sets the period of capacity adjustment

**TW\_COOL\_DIFF** sets the minimum temperature difference between the total leaving water temperature (Tw) and the total leaving water set temperature (TwS) above which the unit will start for cooling mode. When  $T_w - TwS \geq TW\_COOL\_DIFF + 1$ , unit starts. When  $TwoS - Tw \geq 2$  lasts for 5s, unit stops.

**TW\_HEAT\_DIFF** sets the minimum temperature difference between the total leaving water temperature (Tw) and the total leaving water set temperature (TwS) above which the unit will start for heating mode. When  $TwS - Tw \geq TW\_HEAT\_DIFF + 1$ , unit starts. When  $T_w - TwS \geq 1$  lasts for 5s, unit stops.

**RATIO\_COOL\_FIRST** sets the number of initial startup units for cooling mode.

**RATIO\_HEAT\_FIRST** sets the number of initial startup units for heating mode.

### 3.5 SET UNIT PROTECTION

MENU > Project Menu > SET UNIT PROTECTION

SET UNIT PROTECTION	
T_DIFF_PRO	◀ 12 ▶ °C
TWI_O ABNORMAL	◀ 2 ▶ °C
<div style="display: flex; justify-content: space-between; align-items: center;"> <span>OK</span> <span>↕ ▶</span> </div>	

**T\_DIFF\_PRO** set the absolute difference between entering water temperature (Twi) and leaving water temperature (Two). If  $|T_{wi} - T_{wo}| \geq T\_DIFF\_PRO$ , unit stops and error code P9 appears. Normal heat pumps when  $|T_{wi} - T_{wo}| \geq 10^\circ C [T\_DIFF\_PRO]$ , or high temperature heat pumps  $|T_{wi} - T_{wo}| \geq 15^\circ C$ , error code disappears.

**TWI\_O\_ABNORMAL** sets the difference between Inlet water temperature (Twi) and Outlet water temperature (Two). For cooling mode, if  $Two - Twi \geq TWI\_O\_ABNORMAL$  and lasts for 20min, unit stops and error code PA appears. If  $Two - Twi \leq TWI\_O\_ABNORMAL - 1$ , error code disappears. For heating mode, if  $Twi - Two \geq TWI\_O\_ABNORMAL$  and lasts for 20min, unit stops and error code PA appears. If  $Two - Twi \leq TWI\_O\_ABNORMAL - 1$ , error code disappears.

## Hydronic-H Super

### 3.6 SET DEFROSTING

MENU > Project Menu > SET DEFROSTING

SET DEFROSTING	
T_FROST	◀ 35 ▶ min
T_DEFROST_IN	◀ 0 ▶ °C
T_FROST_OUT	◀ 0 ▶ °C
OK [Up/Down]	

**T\_FROST** sets the time between the end of the last defrost mode and the beginning of the next defrost mode.

**T\_DEFROST\_IN** sets the temperature for T3 of entering defrosting mode. When T3 reaches T\_DEFROST\_IN, unit enters defrosting mode.

**T\_FROST\_OUT** sets the temperature for T3 of exiting defrosting model. When T3 reaches T\_DEFROST\_IN, unit exits defrosting mode.

### 3.7 DHW time setting (Customized)

MENU > Project Menu > SET DHW TIME

SET DHW TIME	
SELECT ADDRESS	◀ 07 ▶ #
COOL MAX TIME	◀ 08 ▶ h
COOL MIN TIME	◀ 0.5 ▶ h
HEAT MAX TIME	◀ 08 ▶ h
HEAT MIN TIME	◀ 0.5 ▶ h
OK 1/2 [Up/Down]	

SET DHW TIME	
DHW MIN TIME	◀ 0.5 ▶ h
DHW MAX TIME	◀ 08 ▶ h
OK 2/2 [Up/Down]	

**COOL MAX TIME** sets the maximum operation time for cooling mode when DHW requirement exists.

**COOL MIN TIME** sets the minimum operation time for cooling mode when DHW requirement exists.

**HEAT MAX TIME** sets the maximum operation time for heating mode when DHW requirement exists.

**HEAT MIN TIME** sets the minimum operation time for heating mode when DHW requirement exists.

**DHW MIN TIME** sets the minimum operation time for DHW mode.

**DHW MAX TIME** sets the maximum operation time for DHW mode.

### 3.8 SET E9 TIME

MENU > Project Menu > SET E9 TIME

SET E9 TIME	
E9 PROTECT TIME	◀ 10 ▶ S
E9 DETECTION METHOD	◀ 1 ▶ #
OK [Up/Down]	

**E9 PROTECT TIME** sets the delay time of water flow detection. When unit starts, water flow will not be detected until at least (2+ E9 PROTECT TIME/60) minutes have elapsed.

**E9 DETECTION METHOD** sets the method of water flow detection. If "1" is selected, the water flow switch is detected after water pump starts. If "2" is selected, the water flow switch is both detected before and after the water pump starts.

### 3.9 INV PUMP RATIO

MENU > Project Menu > INV PUMP RATIO

INV PUMP RATIO	
MIN RATIO	◀ 70 ▶ %
MAX RATIO	◀ 100 ▶ %
OK	⬇ ⬅

**MIN RATIO** sets the minimum output ratio of inverter pump which is installed in the main water pipe.

**MAX RATIO** sets the maximum output ratio of inverter pump which is installed in the main water pipe.

### 3.10 CHECK PARTS

MENU > Project Menu > CHECK PARTS

State of different parts can be checked in this menu.

CHECK PARTS	
SELECT ADDRESS	◀ 07 ▶ #
FIX PUMP STATE	OFF
INV PUMP STATE	80%
FOUR-WAY VALVE	OFF
SV1 STATE	OFF
BACK	1/3 ⬇ ⬅

CHECK PARTS	
SV2 STATE	OFF
SV4 STATE	OFF
SV5 STATE	OFF
SV6 STATE	OFF
SV8A STATE	OFF
BACK	2/3 ⬇ ⬅

CHECK PARTS	
SV8B STATE	OFF
HEAT1 STATE	OFF
HEAT2 STATE	OFF
COIL VALVE	OFF
BACK	3/3 ⬇ ⬅

## 4 Parameters setting

Menu	Parameters	Setting range	Default value	Adjustment range
Service menu	TEMP_AUXHEAT_ON	0~10°C	5°C	1°C
	TW_HEAT1_ON	0~50°C	25°C	1°C
	TW_HEAT1_OFF	0~60°C	45°C	1°C
	T_HEAT2_DELAY	60~240min	90min	5min
	DT5_HEAT2_OFF	2~10°C	5°C	1°C
	T4_HEAT2_ON	-5~20°C	5°C	1°C
	T4_COOL_1	15~30°C	25°C	1°C
	T4_COOL_2	35~45°C	40°C	1°C
	OFFSET_C	0~15°C	10°C	1°C
	T4_HEAT_1	-10~10°C	2°C	1°C
	T4_HEAT_2	15~30°C	15°C	1°C
	OFFSET_H	0~30°C	10°C	1°C
	RATIO_PUMP	30%~100%	100%	5%
	PUMP ON TIME	5~60min	5min	5min
	PUMP OFF TIME	0~60min	0min	5min
	MIN TEMP FOR COOL	0~20°C	7°C	1°C
	ENERGY SAVING SWITCH	40~100%	100%	10%

Menu	Parameters	Setting range	Default value	Adjustment range
Project menu	TWO_COOL_DIFF	1°C~5°C	2°C	1°C
	TWO_HEAT_DIFF	1°C~5°C	2°C	1°C
	TIM_CAP_ADJ	60~360s	80s	20s
	TW_COOL_DIFF	1°C~5°C	2°C	1°C
	TW_HEAT_DIFF	1°C~5°C	2°C	1°C
	RATIO_COOL_FIRST	0~100%	50%	5%
	RATIO_HEAT_FIRST	0~100%	50%	5%
	T_DIFF_PRO	Normal: 8~15°C	Normal : 10°C	1°C
		Hot: 8~20°C	Hot: 15°C	
	TWI_O_ABNORMAL	1~5°C	2°C	1°C
	T_FROST	20~120 min	35 min	5min
	T_DEFROST_IN	-5~5°C	0°C	1°C
	T_FROST_OUT	-10~+10°C	0°C	1°C
	E9 PROTECT TIME	2~20s	5s	1
	E9 DETECTION METHOD	1~2	1	1
	MIN RATIO	Normal: 40~100%	75%	5%
Hot: 25~100%		25%	5%	
MAX RATIO	70~100%	100%	5%	
Project menu (customized with DHW)	dT5_ON	2~10°C	8°C	1°C
	dT1S5	5~20°C	10°C	1°C
	COOL MIN TIME	0.5~24h	0.5h	0.5h
	COOL MAX TIME	0.5~24h	8h	0.5h
	HEAT MIN TIME	0.5~24h	0.5h	0.5h
	HEAT MAX TIME	0.5~24h	8h	0.5h
	DHW MIN TIME	0.5~24h	0.5h	0.5h
	DHW MAX TIME	0.5~24h	8h	8h